

# Engineer's Mini-Notebook

Op Amp  
IC Circuits

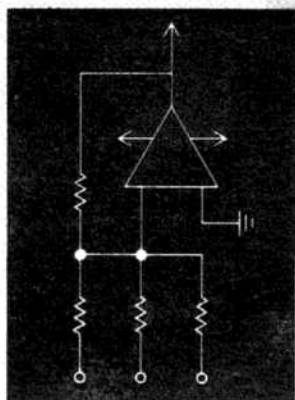

Forrest M. Mims III

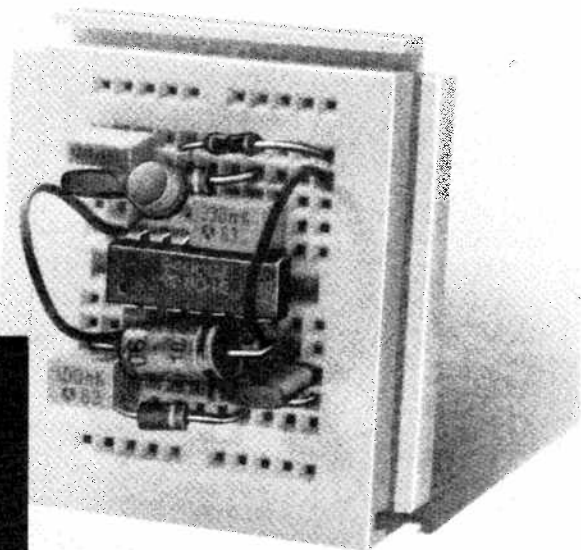

ENGINEER'S  
MINI-NOTEBOOK  
OP-AMP CIRCUITS

BY  
FORREST M. MIMS, III

SECOND EDITION  
THIRD PRINTING-1994  
FOURTH PRINTING-1996  
FIFTH PRINTING-1997

A SILICONCEPTS™ BOOK

COPYRIGHT © 1985 BY FORREST M. MIMS, III  
ALL RIGHTS RESERVED

PRINTED IN THE UNITED STATES OF AMERICA

THIS BOOK INCLUDES STANDARD APPLICATION CIRCUITS AND CIRCUITS DESIGNED BY THE AUTHOR. EACH CIRCUIT WAS ASSEMBLED AND TESTED BY THE AUTHOR AS THE BOOK WAS DEVELOPED. AFTER THE BOOK WAS COMPLETED, THE AUTHOR REASSEMBLED EACH CIRCUIT TO CHECK FOR ERRORS. WHILE REASONABLE CARE WAS EXERCISED IN THE PREPARATION OF THIS BOOK, VARIATIONS IN COMPONENT TOLERANCES AND CONSTRUCTION METHODS MAY CAUSE THE RESULTS YOU OBTAIN TO DIFFER FROM THOSE GIVEN HERE. THEREFORE THE AUTHOR AND RADIO SHACK ASSUME NO RESPONSIBILITY FOR THE SUITABILITY OF THIS BOOK'S CONTENTS FOR ANY APPLICATION. SINCE WE HAVE NO CONTROL OVER THE USE TO WHICH THE INFORMATION IN THIS BOOK IS PUT, WE ASSUME NO LIABILITY FOR ANY DAMAGES RESULTING FROM ITS USE. OF COURSE IT IS YOUR RESPONSIBILITY TO DETERMINE IF COMMERCIAL USE, SALE OR MANUFACTURE OF ANY DEVICE THAT INCORPORATES INFORMATION IN THIS BOOK INFRINGES ANY PATENTS, COPYRIGHTS OR OTHER RIGHTS.

DUE TO THE MANY INQUIRIES RECEIVED BY RADIO SHACK AND THE AUTHOR, IT IS NOT POSSIBLE TO PROVIDE PERSONAL RESPONSES TO REQUESTS FOR ADDITIONAL INFORMATION (CUSTOM CIRCUIT DESIGN, TECHNICAL ADVICE, TROUBLESHOOTING ADVICE, ETC.). IF YOU WISH TO LEARN MORE ABOUT ELECTRONICS, SEE OTHER BOOKS IN THIS SERIES AND RADIO SHACK'S "GETTING STARTED IN ELECTRONICS." ALSO, READ MAGAZINES LIKE POPULAR ELECTRONICS AND RADIO-ELECTRONICS.

# CONTENTS

INTRODUCTION	5
POWERING OP-AMPS	6
OP-AMP SPECIFICATIONS	7
CIRCUIT ASSEMBLY TIPS	7
741C OP-AMP	8
1458 DUAL OP-AMP	9
339 QUAD COMPARATOR	10
386 AUDIO AMPLIFIER	11
CIRCUITS	
BASIC INVERTING AMPLIFIER	12
UNITY GAIN INVERTER	12
NON-INVERTING AMPLIFIER	13
UNITY-GAIN FOLLOWER	13
TRANSCONDUCTANCE AMPLIFIER	14
TRANSIMPEDANCE AMPLIFIER	15
SINGLE-SUPPLY AMPLIFIER	16
AUDIO AMPLIFIER	17
SUMMING AMPLIFIER	18
DIFFERENCE AMPLIFIER	19
DUAL-SUPPLY INTEGRATOR	20
SINGLE-SUPPLY INTEGRATOR	20
DUAL-SUPPLY DIFFERENTIATOR	21
SINGLE-SUPPLY DIFFERENTIATOR	21
PEAK DETECTOR	22
INVERTING CLIPPER	23
NON-INVERTING CLIPPER	23
BISTABLE RS FLIP-FLOP	24
MONOSTABLE MULTIVIBRATOR	25

# CIRCUITS

BASIC COMPARATOR	26-27
BASIC WINDOW COMPARATOR	28-29
3-STEP SEQUENCER	30
BARGRAPH VOLTMETER	31
LIGHT-ACTIVATED RELAYS	32
LIGHT-ACTIVATED ALERTER	33
DARK-ACTIVATED ALERTER	33
LIGHT-SENSITIVE OSCILLATORS	34
HIGH-SENSITIVITY LIGHT METER	35
SOUND-LEVEL METER	36
SOUND-ACTIVATED RELAY	37
PERCUSSION SYNTHESIZER	38
PIEZO ELEMENT DRIVER	39
LOW-PASS FILTER	40
HIGH-PASS FILTER	41
60-Hz NOTCH FILTERS	42
TUNABLE BANDPASS FILTER	43
MINI-COLOR ORGAN	44-45
SQUARE WAVE GENERATOR	46
SINE WAVE OSCILLATOR	47
FUNCTION GENERATOR	48

## HISTORICAL NOTE

THE OPERATIONAL AMPLIFIER WAS DEVELOPED FOR USE IN ANALOG COMPUTERS IN THE 1940s. EARLY OP-AMPS USED VACUUM TUBES AND WERE LARGE IN SIZE AND CONSUMED CONSIDERABLE POWER. IN 1967 FAIRCHILD SEMICONDUCTOR INTRODUCED THE FIRST INTEGRATED CIRCUIT OP-AMP. TODAY'S IC OP-AMPS ARE FAR SUPERIOR TO THEIR VACUUM TUBE PREDECESSORS. AND THEY ARE MUCH SMALLER AND CAN BE PURCHASED FOR AS LITTLE AS A DOLLAR OR TWO.

# INTRODUCTION

THE OPERATIONAL AMPLIFIER OR OP-AMP IS A HIGH PERFORMANCE LINEAR AMPLIFIER WITH AN AMAZING VARIETY OF USES. THE OP-AMP HAS TWO INPUTS, INVERTING (-) AND NON-INVERTING (+), AND ONE OUTPUT. THE POLARITY OF A SIGNAL APPLIED TO THE INVERTING INPUT IS REVERSED AT THE OUTPUT. A SIGNAL APPLIED TO THE NON-INVERTING INPUT RETAINS ITS POLARITY AT THE OUTPUT.

THE GAIN (DEGREE OF AMPLIFICATION) OF AN OP-AMP IS DETERMINED BY A FEEDBACK RESISTOR THAT FEEDS SOME OF THE AMPLIFIED SIGNAL FROM THE OUTPUT TO THE INVERTING INPUT. THIS REDUCES THE AMPLITUDE OF THE OUTPUT SIGNAL, HENCE THE GAIN. THE SMALLER THE RESISTOR, THE LOWER THE GAIN.

HERE IS A BASIC INVERTING AMPLIFIER MADE WITH AN OP-AMP:

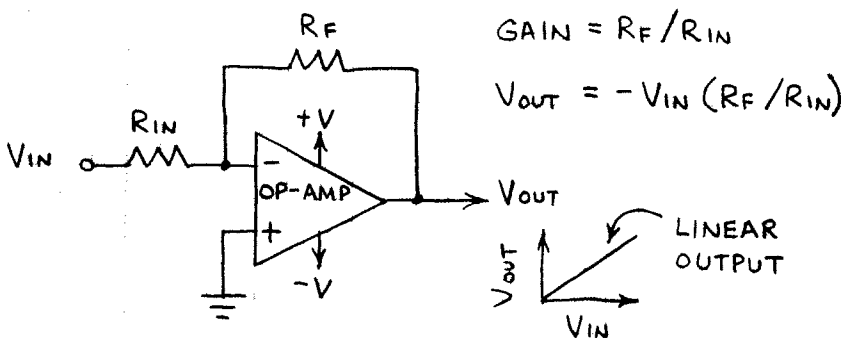

THE GAIN IS INDEPENDENT OF THE SUPPLY VOLTAGE. NOTE THAT THE UNUSED INPUT IS GROUNDED. THEREFORE THE OP-AMP AMPLIFIES THE DIFFERENCE BETWEEN THE INPUT ( $V_{IN}$ ) AND GROUND (0 VOLTS). THE OP-AMP IS THEN A DIFFERENTIAL AMPLIFIER.

THE FEEDBACK RESISTOR ( $R_f$ ) AND AN OP-AMP FORM A CLOSED FEEDBACK LOOP. WHEN  $R_f$  IS OMITTED, THE OP-AMP IS SAID TO BE IN ITS OPEN LOOP MODE. THE OP-AMP THEN EXHIBITS MAXIMUM GAIN, BUT ITS OUTPUT THEN SWINGS FROM FULL ON TO FULL OFF OR VICE VERSA FOR VERY SMALL CHANGES IN INPUT VOLTAGE. THEREFORE THE OPEN LOOP MODE IS NOT PRACTICAL FOR LINEAR AMPLIFICATION. INSTEAD THIS MODE IS USED TO INDICATE WHEN THE VOLTAGE AT ONE INPUT DIFFERS FROM THAT AT THE OTHER. IN THIS MODE THE OP-AMP IS CALLED A COMPARATOR SINCE IT COMPARES ONE INPUT VOLTAGE WITH THE OTHER.

## POWERING OP-AMPS

MOST OP-AMPS AND OP-AMP CIRCUITS REQUIRE A DUAL POLARITY POWER SUPPLY. HERE IS A SIMPLE DUAL POLARITY SUPPLY MADE FROM TWO 9-VOLT BATTERIES:

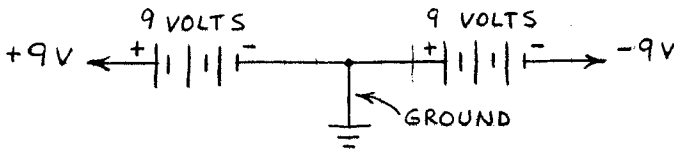

IMPORTANT: THE LEADS FROM THE SUPPLY TO THE OP-AMP SHOULD BE SHORT AND DIRECT. IF THEY EXCEED ABOUT 6 INCHES, THE OP-AMP'S SUPPLY PINS MUST BE BYPASSED BY CONNECTING A  $0.1 \mu\text{F}$  CAPACITOR BETWEEN EACH POWER SUPPLY PIN AND GROUND. OTHERWISE THE OP-AMP MAY OSCILLATE OR FAIL TO OPERATE PROPERLY. ALWAYS USE FRESH BATTERIES. BOTH MUST SUPPLY THE SAME VOLTAGE. BE SURE THE BATTERY CLIPS ARE CLEAN AND TIGHT. NEVER APPLY AN INPUT SIGNAL WHEN THE POWER SUPPLY IS SWITCHED OFF.



# OP-AMP SPECIFICATIONS

OP-AMPS ARE CHARACTERIZED BY DOZENS OF SPECIFICATIONS, SOME OF WHICH ARE GIVEN ON THE FOLLOWING PAGES. THOSE WHOSE MEANING IS NOT OBVIOUS ARE:

**INPUT OFFSET VOLTAGE** - EVEN WITH NO INPUT VOLTAGE AN OP-AMP GIVES A VERY SMALL OUTPUT VOLTAGE. THE OFFSET VOLTAGE IS THAT WHICH, WHEN APPLIED TO ONE INPUT, CAUSES THE OUTPUT TO BE AT 0 VOLTS.

**COMMON MODE REJECTION RATIO** - THIS IS A MEASURE OF THE ABILITY OF AN OP-AMP TO REJECT A SIGNAL SIMULTANEOUSLY APPLIED TO BOTH INPUTS.

**BANDWIDTH** - THE FREQUENCY RANGE OVER WHICH AN OP-AMP WILL FUNCTION. THE FREQUENCY AT WHICH THE GAIN FALLS TO 1 IS THE UNITY GAIN FREQUENCY.

**SLEW RATE** - THE RATE OF CHANGE IN THE OUTPUT OF AN OP-AMP IN VOLTS PER MICROSECOND WHEN THE GAIN IS 1.

# CIRCUIT ASSEMBLY TIPS

YOU CAN USUALLY SUBSTITUTE DIFFERENT OP-AMPS IN A CIRCUIT. FOR EXAMPLE, USE A 1458 DUAL OP-AMP IN A CIRCUIT THAT REQUIRES TWO 741 OP-AMPS. BE SURE TO KEEP TRACK OF PIN DIFFERENCES. FOR VERY HIGH INPUT RESISTANCE AND LOW OPERATING CURRENT, USE CMOS OP-AMPS. USE A HIGH-IMPEDANCE VOLTMETER TO MONITOR THE OUTPUT OF AN OP-AMP THAT IS AMPLIFYING A D.C. VOLTAGE. IF A CIRCUIT FAILS TO WORK, REMOVE INPUT SIGNAL FIRST. THEN DISCONNECT POWER AND CHECK THE WIRING. USE FRESH BATTERIES.

# 741 OP-AMP

THE 741 IS A HIGHLY POPULAR GENERAL PURPOSE OP-AMP. IT IS SIMPLE TO USE, RELIABLE, AND INEXPENSIVE. IT IS USED IN MOST CIRCUITS IN THIS BOOK.

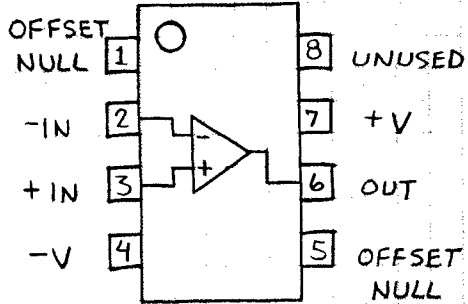

## MAXIMUM RATINGS

SUPPLY VOLTAGE	$\pm 18$ V
POWER DISSIPATION	500 mW
DIFFERENTIAL INPUT VOLTAGE	$\pm 30$ V
INPUT VOLTAGE (NOTE 1)	$\pm 15$ V
OUTPUT SHORT CIRCUIT TIME	INDEFINITE
OPERATING TEMPERATURE	$0^{\circ}\text{C}$ TO $70^{\circ}\text{C}$

NOTE 1: INPUT VOLTAGE SHOULD NOT EXCEED SUPPLY VOLTAGE WHEN SUPPLY VOLTAGE IS LESS THAN  $\pm 15$  VOLTS.

## CHARACTERISTICS (NOTE 2)

INPUT OFFSET VOLTAGE	2 TO 6 mV
INPUT RESISTANCE	.3 TO 2 M $\Omega$
VOLTAGE GAIN	20,000 TO 200,000
COMMON-MODE REJECTION RATIO	70 TO 90 dB
BANDWIDTH	.5 TO 1.5 MHz
SLEW RATE	.5 V / $\mu\text{SEC}$
SUPPLY CURRENT	1.7 TO 2.8 mA
POWER CONSUMPTION	50 TO 85 mW

NOTE 2: VALUES SHOWN ARE TYPICAL OR MINIMUM TO TYPICAL.

# 1458 DUAL OP-AMP

THE 1458 INCLUDES TWO INDEPENDENT, GENERAL PURPOSE OP-AMPS IN A SINGLE PACKAGE. THE AMPLIFIERS SHARE COMMON POWER SUPPLY PINS. USE TO REPLACE TWO 741 OP-AMPS.

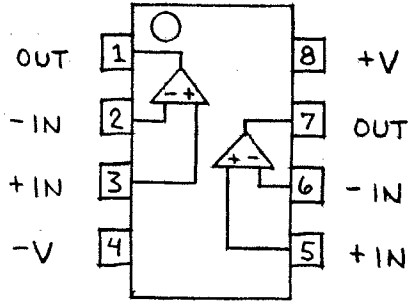

## MAXIMUM RATINGS

SUPPLY VOLTAGE	$\pm 18$ V
POWER DISSIPATION	400 mW
DIFFERENTIAL INPUT VOLTAGE	$\pm 30$ V
INPUT VOLTAGE (NOTE 1)	$\pm 15$ V
OUTPUT SHORT CIRCUIT TIME	INDEFINITE
OPERATING TEMPERATURE	0°C TO 70°C

NOTE 1: INPUT VOLTAGE SHOULD NOT EXCEED SUPPLY VOLTAGE WHEN SUPPLY VOLTAGE IS LESS THAN  $\pm 15$  V.

## CHARACTERISTICS (NOTE 2)

INPUT OFFSET VOLTAGE	1 TO 6 mV
INPUT RESISTANCE	.3 TO 1 M $\Omega$
VOLTAGE GAIN	20,000 TO 160,000
COMMON-MODE REJECTION RATIO	70 TO 90 dB
SUPPLY CURRENT (NOTE 3)	3 TO 5.6 mA
POWER CONSUMPTION	85 mW

NOTE 2: VALUES SHOWN ARE TYPICAL OR MINIMUM TO TYPICAL.

NOTE 3: BOTH AMPLIFIERS.

# 339 QUAD COMPARATOR

THE 339 CONTAINS FOUR INDEPENDENT COMPARATORS, MAKING IT AN ECONOMICAL APPROACH TO COMPARATOR CIRCUITS. IT OPERATES FROM A SINGLE POLARITY POWER SUPPLY.

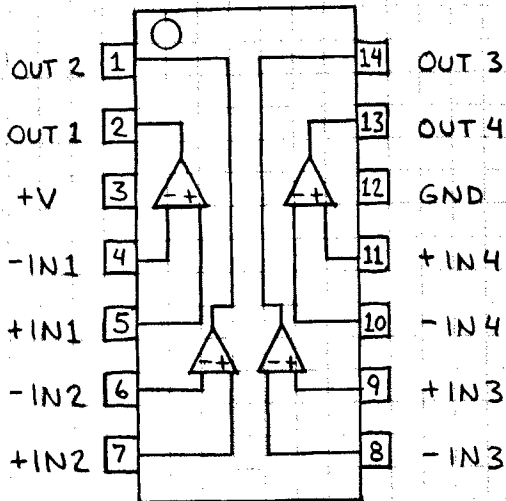

## MAXIMUM RATINGS

SUPPLY VOLTAGE	+36V OR ±18V
POWER DISSIPATION	570 mW
DIFFERENTIAL INPUT VOLTAGE	36 V
INPUT VOLTAGE	-.3V TO +36V
OUTPUT SHORT CIRCUIT (NOTE 1)	CONTINUOUS
OPERATING TEMPERATURE	0°C TO 70°C

NOTE 1: OK TO SHORT OUTPUT TO GROUND. DO NOT SHORT OUTPUT TO +V SINCE CHIP WILL OVERHEAT.

## CHARACTERISTICS (NOTE 2)

INPUT OFFSET VOLTAGE	±3 TO ±20 mV
VOLTAGE GAIN	2,000 TO 30,000
SUPPLY CURRENT	.8 TO 2 mA
OUTPUT SINK CURRENT	6 TO 16 mA

NOTE 2: VALUES SHOWN ARE MINIMUM TO TYPICAL.

# 386 AUDIO AMPLIFIER

SIMPLE TO USE  
AUDIO AMPLIFIER  
WITH GAIN OF  
20. OPERATES  
FROM SINGLE  
POLARITY SUPPLY.  
CONNECT  $10\mu\text{F}$   
CAPACITOR BETWEEN  
PINS 1 AND 8 FOR  
GAIN OF 200.

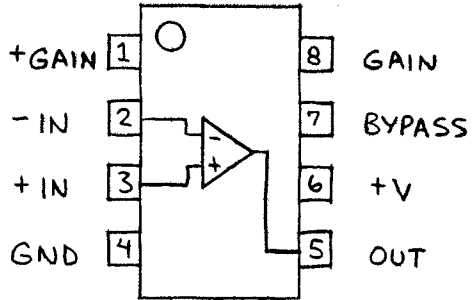

## MAXIMUM RATINGS

SUPPLY VOLTAGE	+15 V
POWER DISSIPATION	660 mW
INPUT VOLTAGE	$\pm 0.4$ V
OPERATING TEMPERATURE	0°C TO 70°C

## CHARACTERISTICS

SUPPLY VOLTAGE RANGE	+4 TO +12 V
STANDBY CURRENT	4 TO 8 mA
OUTPUT POWER	250 TO 325 mW
VOLTAGE GAIN	20 TO 200
BANDWIDTH	300 KHz
TOTAL HARMONIC DISTORTION	0.2 %
INPUT RESISTANCE	50K $\Omega$

## TYPICAL APPLICATION

GAIN = 20

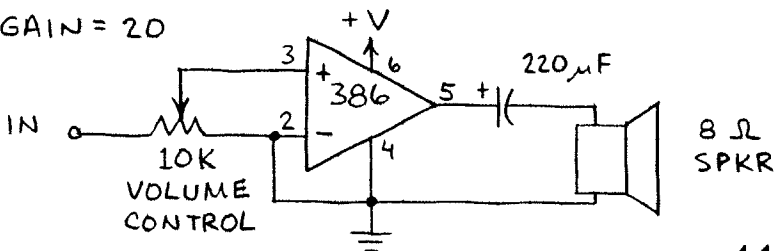

# BASIC INVERTING AMPLIFIER

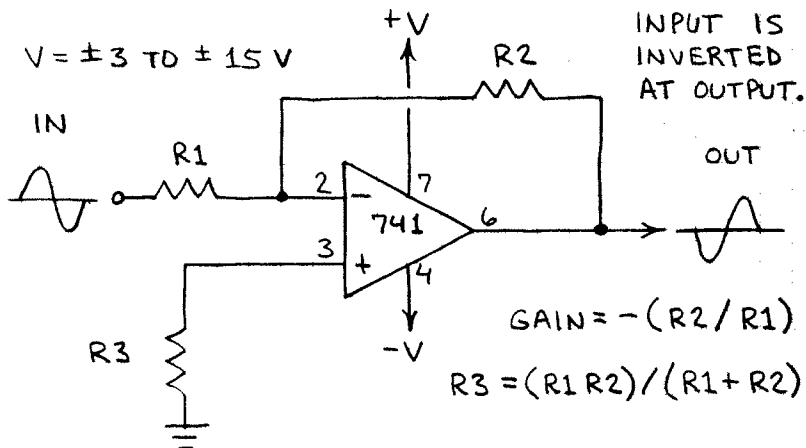

EXAMPLE: IF  $R1 = 1000 \text{ OHMS}$  AND  $R2 = 10,000 \text{ OHMS}$ , THEN GAIN IS  $-(10,000/1000)$  OR  $-10$ .

THIS IS ONE OF THE MOST COMMON OP-AMP CIRCUITS. FOR A NON-INVERTED OUTPUT USE THE AMPLIFIER ON THE FACING PAGE.

# UNITY-GAIN INVERTER

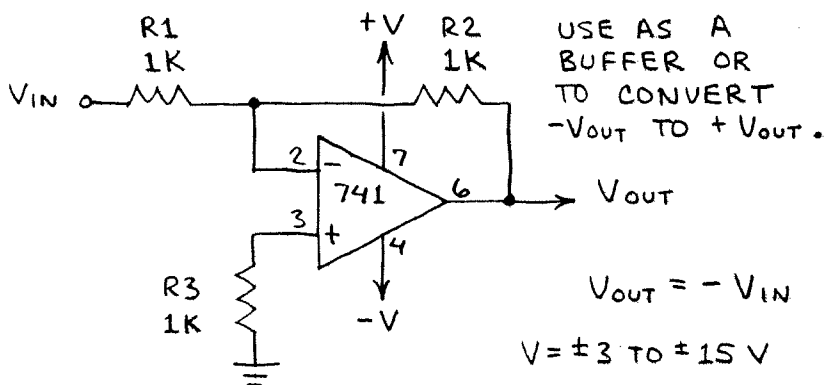

# NON-INVERTING AMPLIFIER

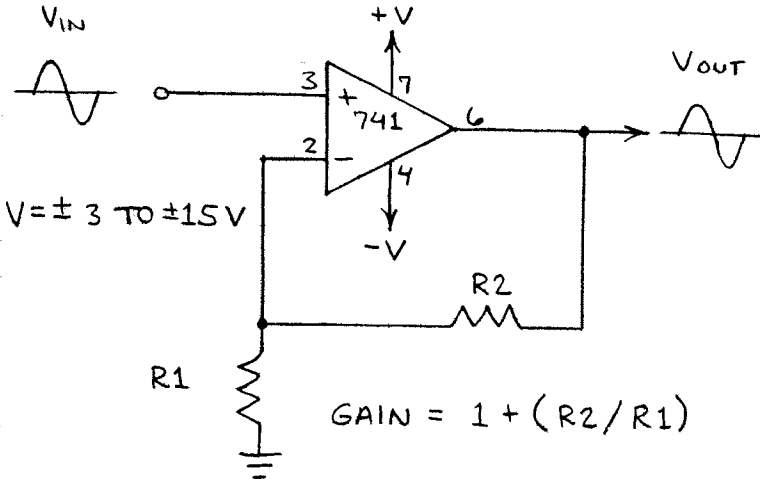

EXAMPLE: IF  $R_1 = 1,000 \text{ OHMS}$  AND  $R_2 = 10,000 \text{ OHMS}$ , THEN GAIN IS  $1 + (10,000 / 1,000)$  OR 11.

NOTE THAT  $V_{OUT}$  IS AN AMPLIFIED BUT NOT INVERTED VERSION OF  $V_{IN}$ .

# UNITY-GAIN FOLLOWER

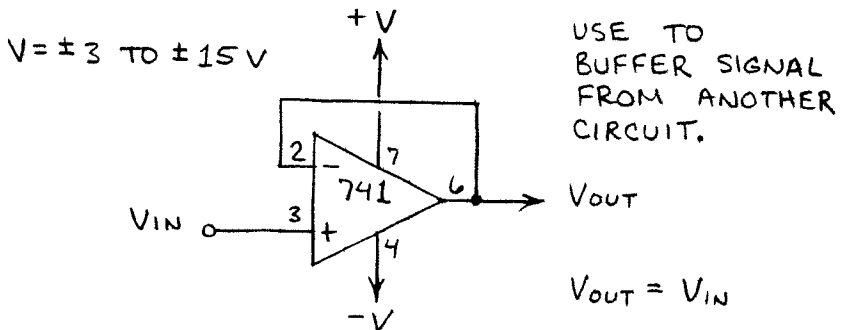

# TRANSCONDUCTANCE AMPLIFIER

$V = \pm 3 \text{ TO } \pm 15\text{V}$

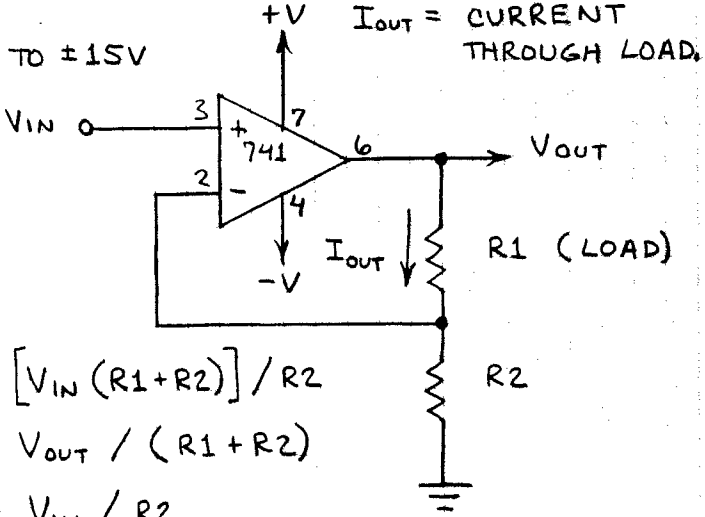

$$V_{OUT} = [V_{IN} (R_1 + R_2)] / R_2$$

$$I_{OUT} = V_{OUT} / (R_1 + R_2)$$

$$I_{OUT} = V_{IN} / R_2$$

THIS CIRCUIT IS A VOLTAGE-TO-CURRENT CONVERTER. HERE'S HOW IT PERMITS AN INPUT VOLTAGE TO CONTROL THE BRIGHTNESS OF AN LED:

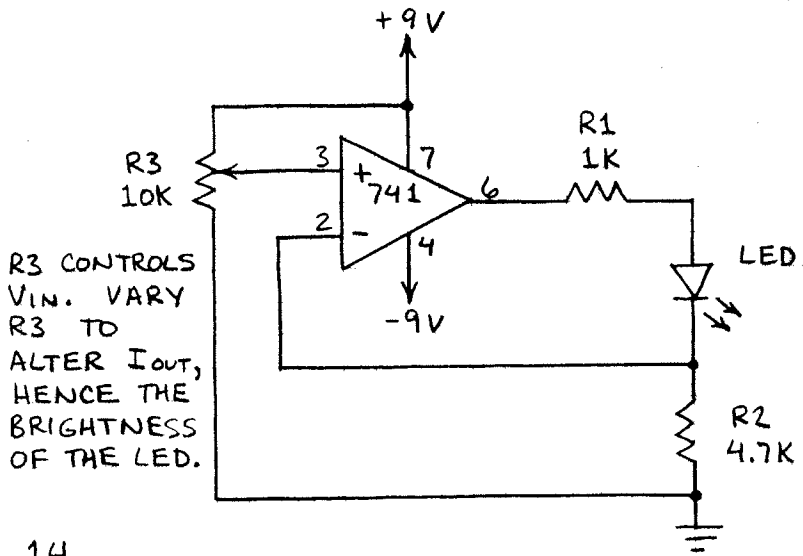

R3 CONTROLS  $V_{IN}$ . VARY R3 TO ALTER  $I_{OUT}$ , HENCE THE BRIGHTNESS OF THE LED.



# TRANSIMPEDANCE AMPLIFIER

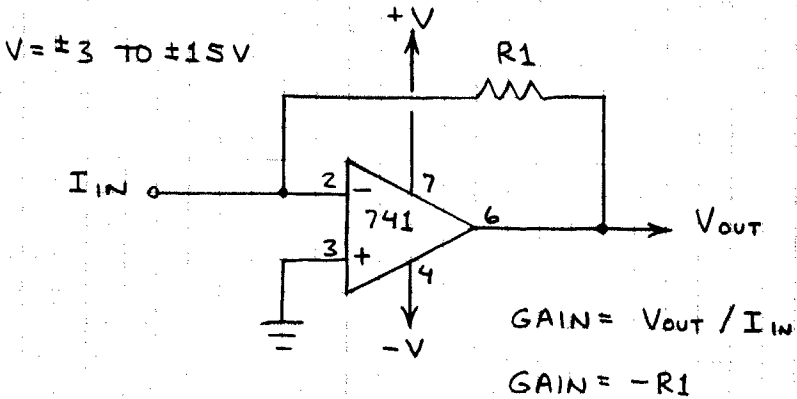

EXAMPLE: IF  $R1 = 1,000 \text{ OHMS}$  THEN  $GAIN = -1,000$ .

THIS CIRCUIT IS A CURRENT-TO-VOLTAGE CONVERTER. HERE'S HOW IT TRANSFORMS THE CURRENT GENERATED BY A SOLAR CELL INTO AN OUTPUT VOLTAGE:

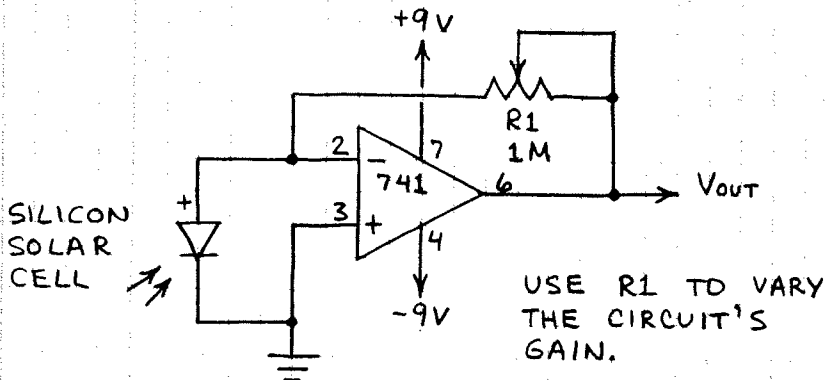

THIS CIRCUIT CAN AMPLIFY THE SIGNAL FROM NON-CURRENT GENERATORS LIKE THERMISTORS AND PHOTORESISTORS. CONNECT ONE SIDE OF DEVICE TO  $+9\text{V}$  AND THE OTHER TO PIN 2. GROUND PIN 3.

# SINGLE-SUPPLY AMPLIFIER

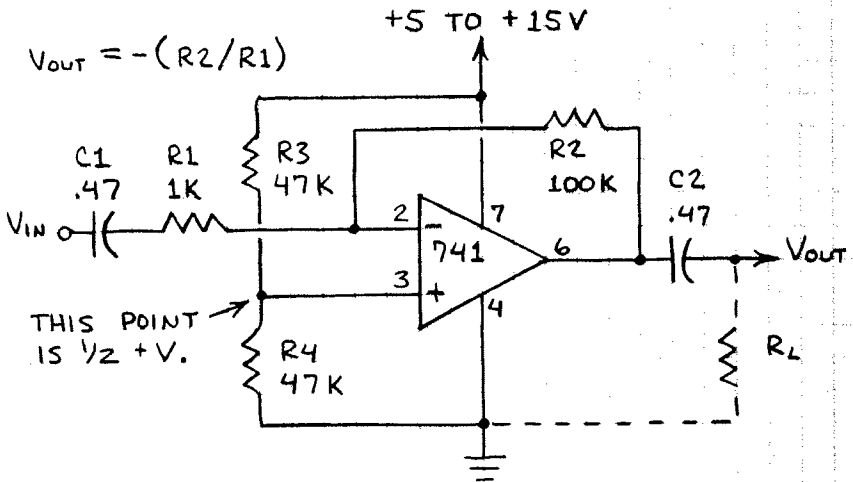

THIS IS AN INVERTING AMPLIFIER DESIGNED TO OPERATE FROM A SINGLE-POLARITY SUPPLY. WITH THE VALUES FOR  $R1$  AND  $R2$  GIVEN ABOVE, THE GAIN IS 100. CAPACITORS  $C1$  AND  $C2$  MUST BE USED. THEREFORE THIS CIRCUIT WILL AMPLIFY A FLUCTUATING AC SIGNAL BUT NOT A DC SIGNAL.

$C1$  SHOULD BE APPROXIMATELY  $1/(2\pi f_{low} R1)$ . (FLOW IS THE LOW FREQUENCY CUTOFF OR 300 HZ FOR THE CIRCUIT ABOVE.)  $C2$  SHOULD BE APPROXIMATELY  $1/(2\pi f_{low} R_L)$ . ( $R_L$  IS THE LOAD RESISTANCE.)

THE OUTPUT FROM A DUAL-SUPPLY OP-AMP CAN FLUCTUATE ABOVE AND BELOW GROUND (0 VOLTS). HERE THE DIVIDER FORMED BY  $R3$  AND  $R4$  SETS  $V_{out}$  AT  $1/2 +V$ . THE OUTPUT THEN FLUCTUATES ABOVE AND BELOW  $1/2 +V$  LIKE THIS:

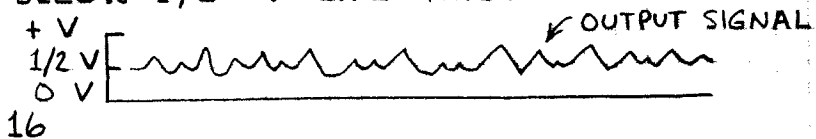

# AUDIO AMPLIFIER

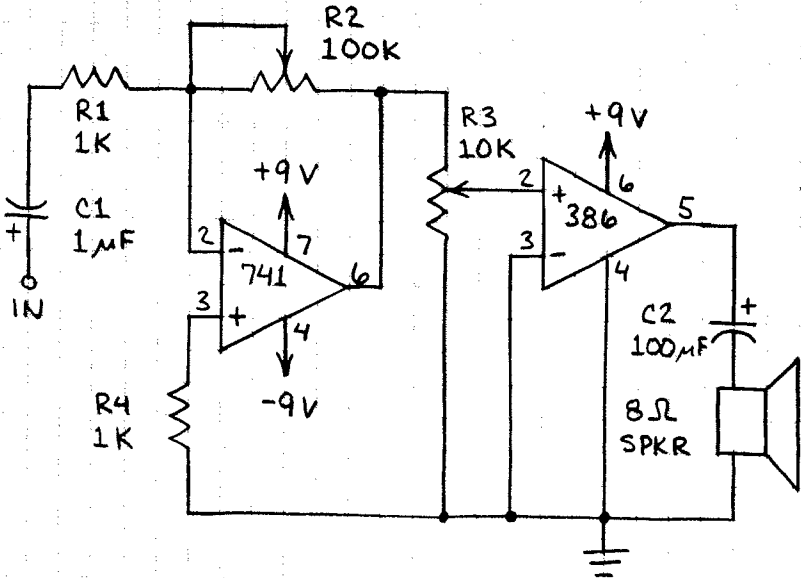

THE 741 IS A PREAMPLIFIER. R2 CONTROLS ITS GAIN. THE 386 IS A POWER AMPLIFIER. R3 CONTROLS THE VOLUME OF THE SPEAKER. OK TO USE FIXED 100K RESISTOR FOR R2. (REDUCE RESISTANCE OF R2 IF CIRCUIT OSCILLATES OR GIVES DISTORTED OUTPUT.) IMPORTANT: BYPASS THE POWER SUPPLY CONNECTIONS WITH 0.1μF CAPACITORS.

# AUDIO MIXER

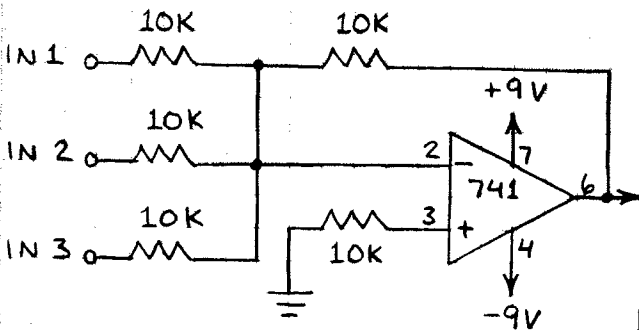

OK TO USE WITH THE AMPLIFIER ABOVE.

OUTPUT

USE WITH MULTIPLE MICROPHONES.

# SUMMING AMPLIFIER

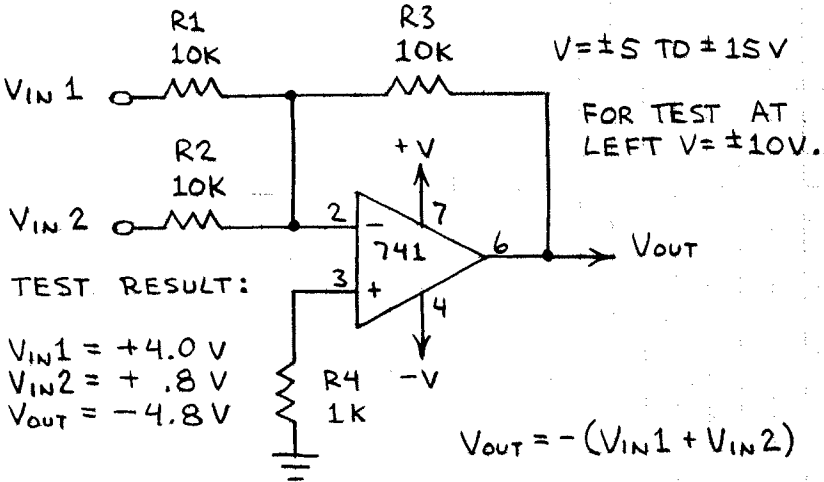

THE OUTPUT OF THE SUMMING AMPLIFIER IS THE SUM OF THE INPUT VOLTAGES. THE SUM OF THE INPUTS SHOULD NOT EXCEED  $\pm V$  LESS A VOLT OR TWO. OK TO ADD MORE INPUTS. (USE 10K RESISTOR TO PIN 2 FOR EACH INPUT.) THE CIRCUIT BELOW PRESERVES THE POLARITY OF  $V_{IN}$ :

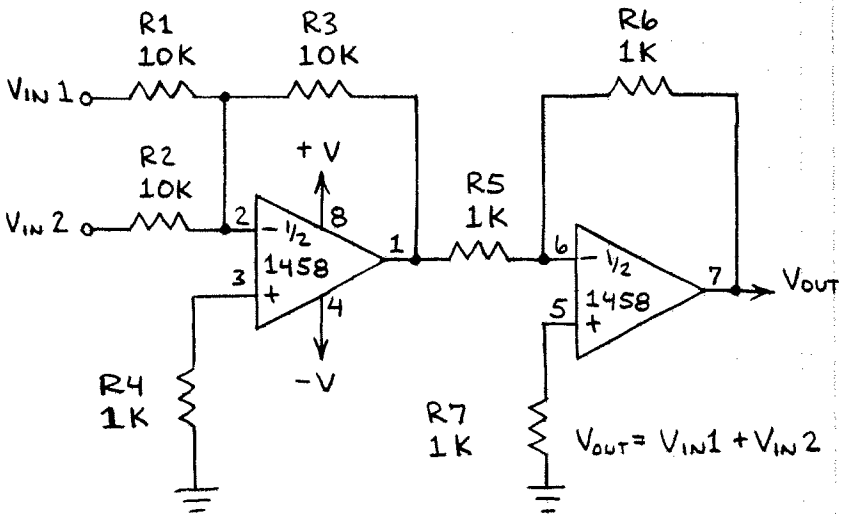

# DIFFERENCE AMPLIFIER

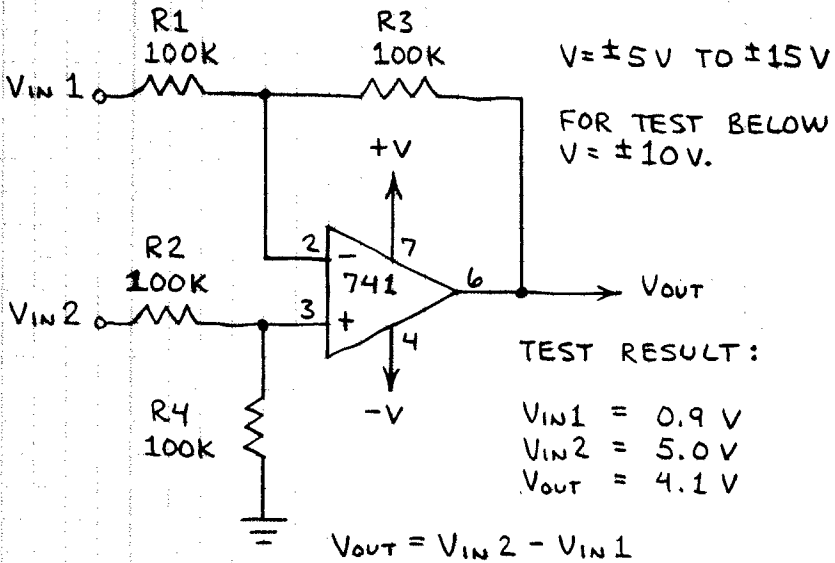

THE OUTPUT OF THE DIFFERENCE AMPLIFIER IS  $V_{IN2} - V_{IN1}$ . THE INPUT VOLTAGES SHOULD NOT EXCEED  $\pm V$ . THE CIRCUIT BELOW REVERSES THE POLARITY OF  $V_{IN2} - V_{IN1}$ :

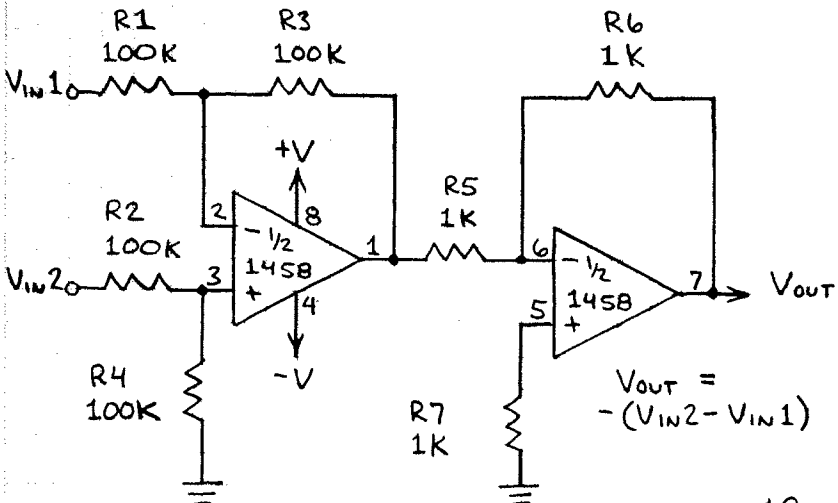

# DUAL-SUPPLY INTEGRATOR

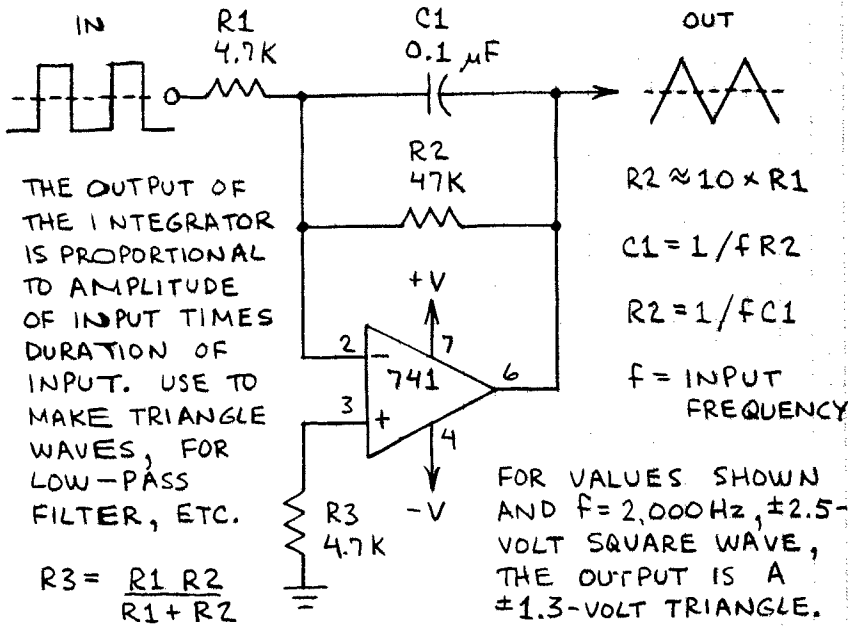

# SINGLE-SUPPLY INTEGRATOR

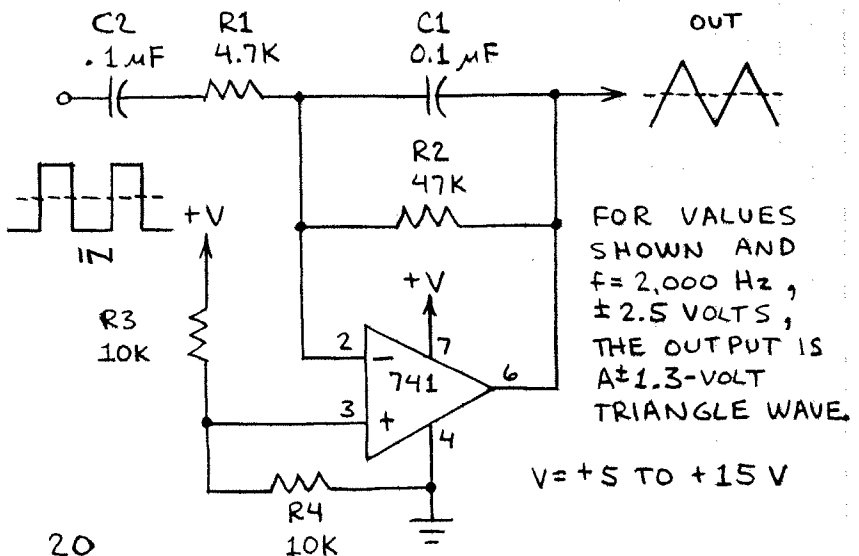

# DUAL-SUPPLY DIFFERENTIATOR

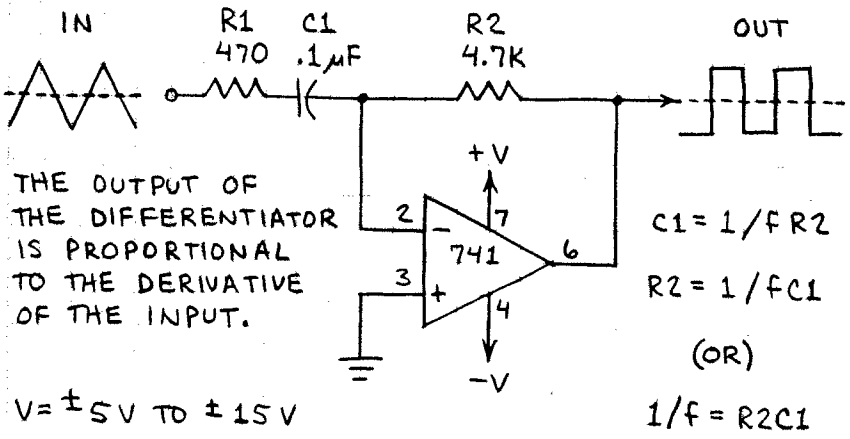

FOR VALUES SHOWN AND  $f = 2,000 \text{ Hz}$ ,  $\pm 2.5$ -VOLT TRIANGLE WAVE, THE OUTPUT IS A  $\pm 10$ -VOLT SQUARE WAVE.

THE DIFFERENTIATOR WILL TRANSFORM A SQUARE WAVE INTO PULSES:

$f = 2,000 \text{ Hz}$ ,  $V = \pm 10 \text{ V}$   
 $IN = \pm 0.5 \text{ V}$ ,  $OUT = \pm 7 \text{ V}$

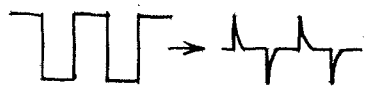

# SINGLE-SUPPLY DIFFERENTIATOR

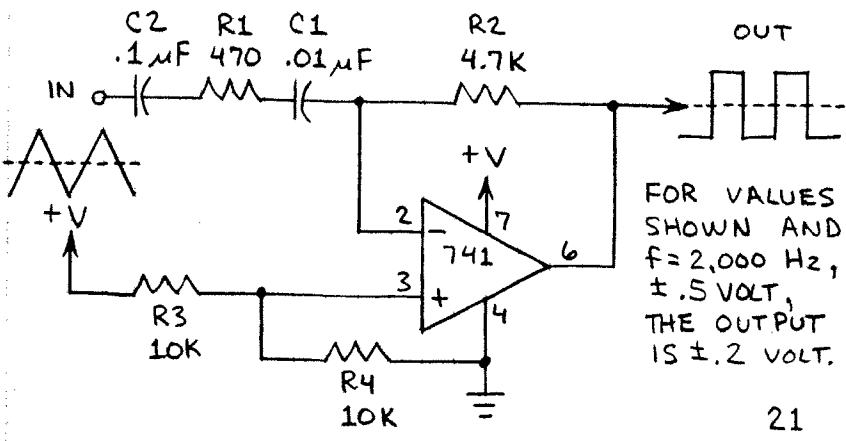

# PEAK DETECTOR

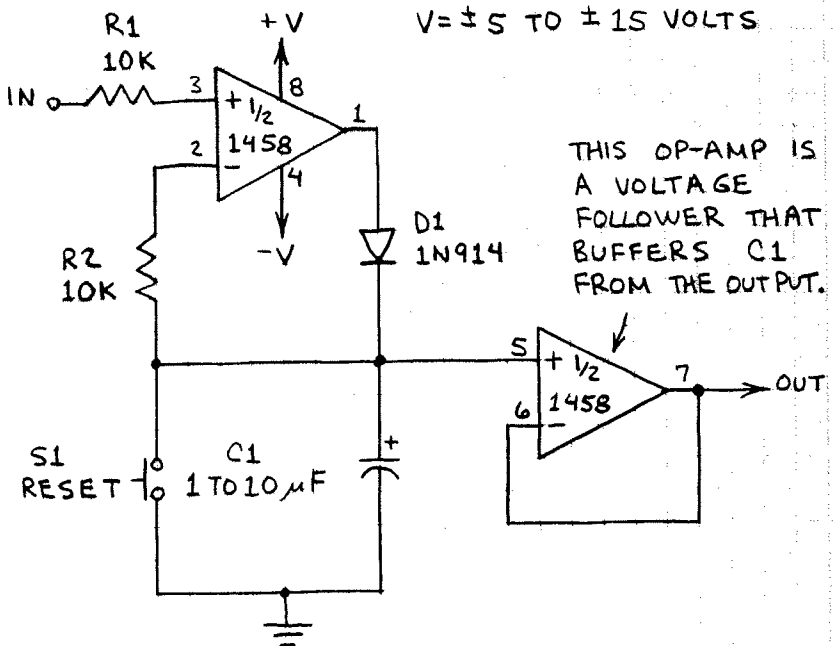

THIS CIRCUIT FOLLOWS AN INCOMING VOLTAGE SIGNAL AND STORES THE MAXIMUM VOLTAGE IN C1. PRESS S1 TO DISCHARGE C1 AND RESET CIRCUIT. CONNECT A VOLTMETER FROM OUTPUT TO GROUND TO MEASURE THE PEAK VOLTAGE STORED IN C1. THE CIRCUIT FUNCTIONS LIKE THIS:

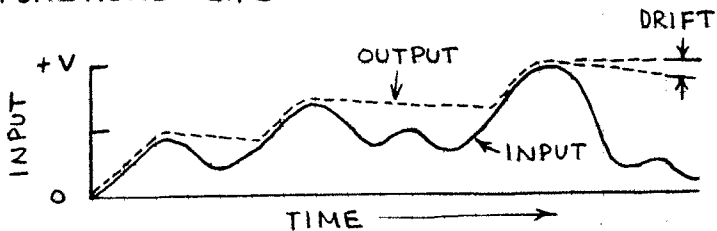

NOTE HOW THE OUTPUT FOLLOWS THE PRECEDING HIGH (PEAK) INPUT. ALSO NOTE THAT THE CHARGE ON C1 WILL GRADUALLY LEAK AWAY, C1 IN THE TEST CIRCUIT FELL 10 MILLIVOLTS / SECOND.



# INVERTING CLIPPER

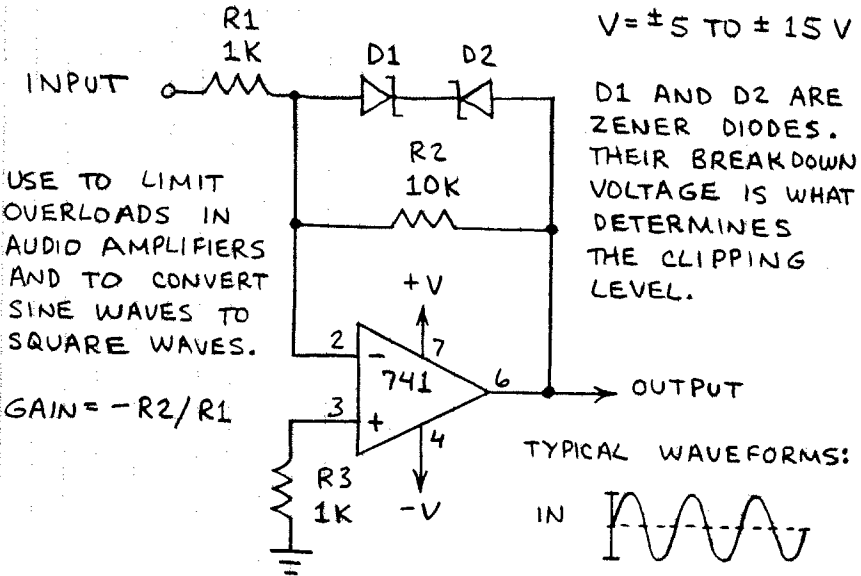

USE TO LIMIT OVERLOADS IN AUDIO AMPLIFIERS AND TO CONVERT SINE WAVES TO SQUARE WAVES.

GAIN =  $-R2/R1$

$V = \pm 5$  TO  $\pm 15$  V

D1 AND D2 ARE ZENER DIODES. THEIR BREAKDOWN VOLTAGE IS WHAT DETERMINES THE CLIPPING LEVEL.

TYPICAL WAVEFORMS:

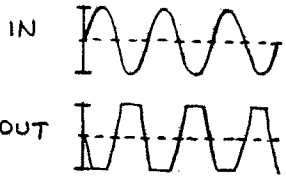

VALUES SHOWN GIVE  $-(\times 10)$  GAIN.  $D1 = D2 = 5$  VOLTS.

# NON-INVERTING CLIPPER

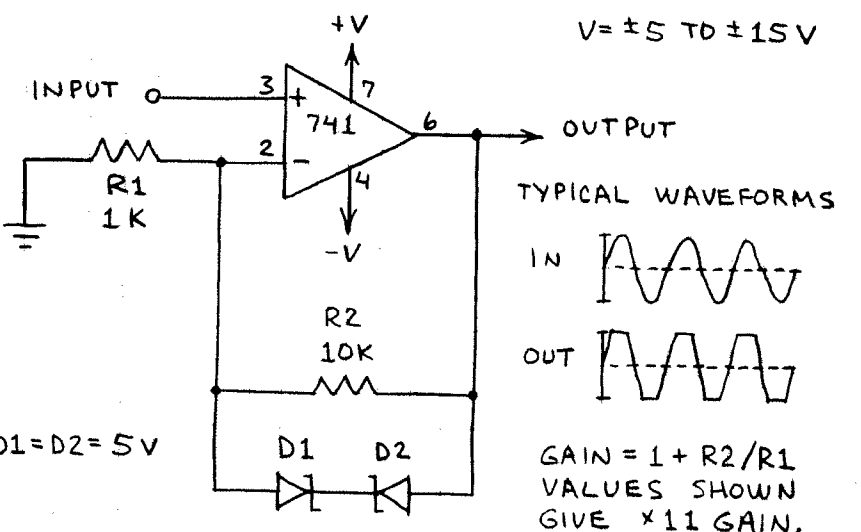

$V = \pm 5$  TO  $\pm 15$  V

TYPICAL WAVEFORMS

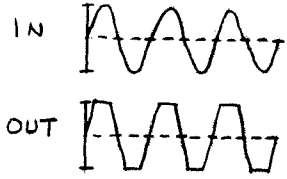

$D1 = D2 = 5$  V

GAIN =  $1 + R2/R1$   
VALUES SHOWN GIVE  $\times 11$  GAIN.

# BISTABLE RS FLIP-FLOP

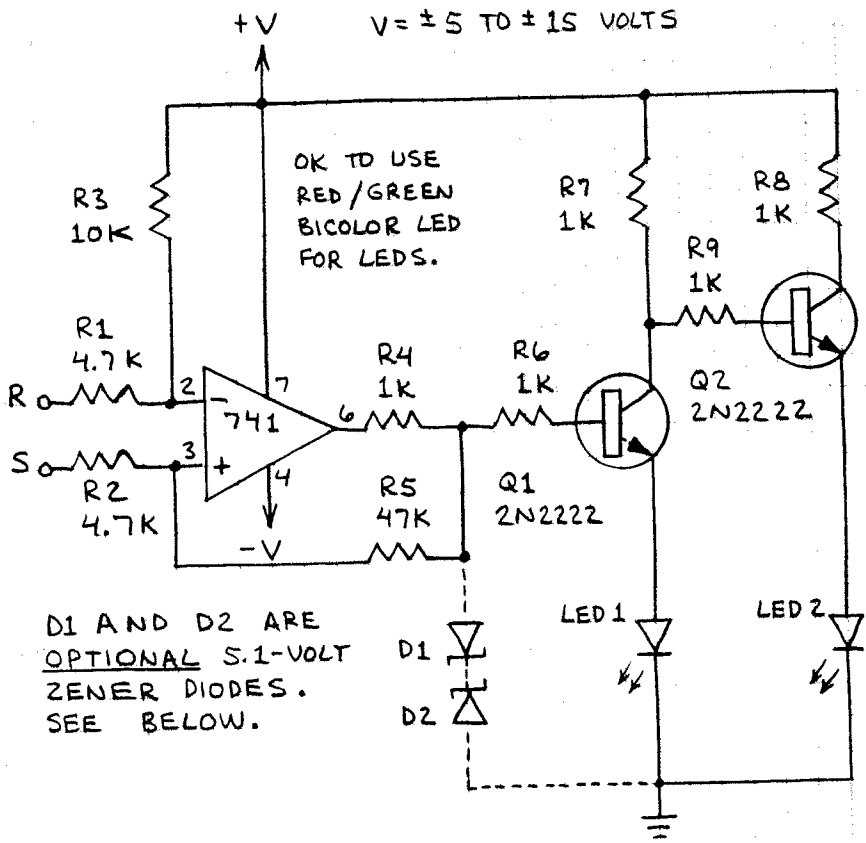

THIS CIRCUIT DEMONSTRATES HOW AN ANALOG CHIP CAN PERFORM A DIGITAL LOGIC FUNCTION. (THE COMPARATOR IS ANOTHER EXAMPLE.)  
HERE IS THE TRUTH TABLE:

INPUT		LED	
R	S	1	2
GND	+V	ON	OFF
GND	-V	OFF	ON
+V	GND	OFF	ON
-V	GND	ON	OFF

← THESE OUTPUTS  
← HAVE MEMORY  
AND HOLD THEIR  
STATE EVEN WHEN  
S INPUT FLOATS.

USE D1 AND D2 TO  
LIMIT OUTPUT LEVEL.

# MONOSTABLE MULTIVIBRATOR

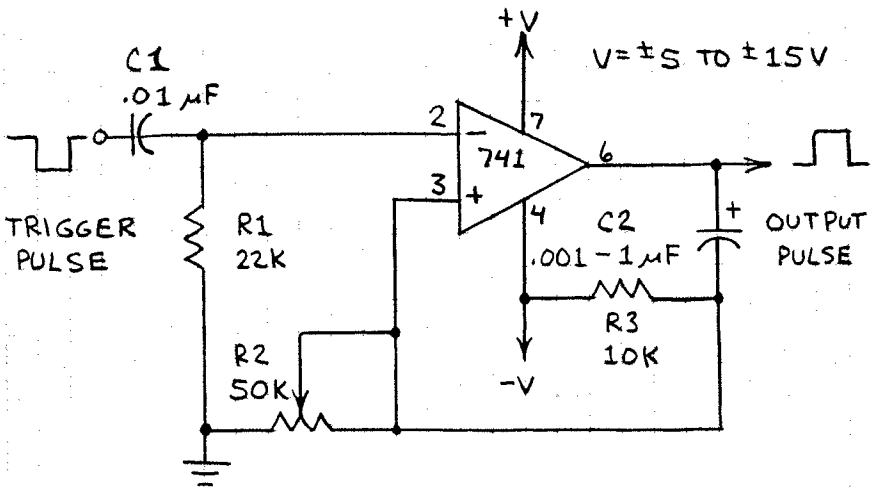

A NEGATIVE TRIGGER PULSE CAUSES THE OP-AMP OUTPUT TO SWING FROM LOW TO HIGH FOR A TIME APPROXIMATELY EQUAL TO  $R_2 \times C_2$ . USE TO DIVIDE AN INCOMING SIGNAL AND TO CONVERT AN IRREGULAR INPUT PULSE TO A UNIFORM OUTPUT PULSE. TYPICAL RESULTS:

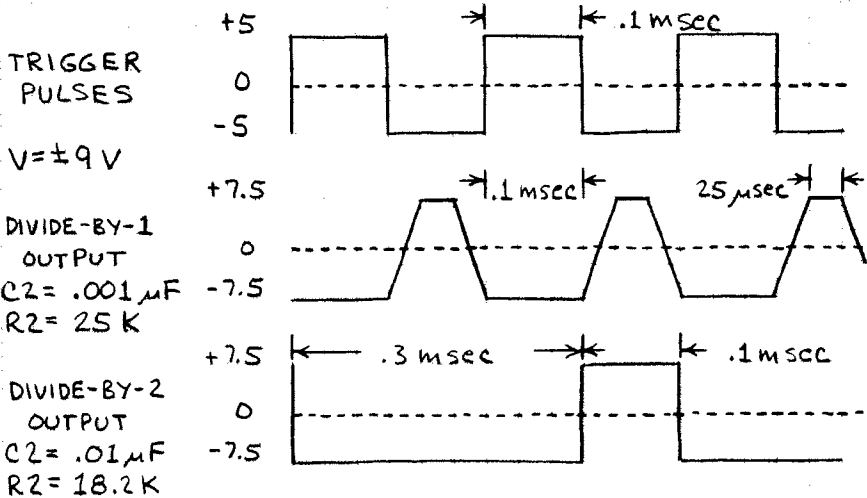

NOTE: USE THE 555 FOR MORE VERSATILITY.

# BASIC COMPARATOR

A COMPARATOR IS AN ANALOG CIRCUIT THAT MONITORS TWO INPUT VOLTAGES. ONE VOLTAGE IS CALLED THE REFERENCE VOLTAGE ( $V_{REF}$ ) AND THE OTHER IS CALLED THE INPUT VOLTAGE ( $V_{IN}$ ). WHEN  $V_{IN}$  RISES ABOVE OR FALLS BELOW  $V_{REF}$ , THE OUTPUT OF THE COMPARATOR CHANGES STATES. SOME CIRCUITS (LIKE THE 339) ARE DESIGNED SPECIFICALLY AS COMPARATORS. DUE TO ITS VERY HIGH OPEN-LOOP GAIN, AN OP-AMP WITHOUT A FEEDBACK RESISTOR CAN FUNCTION AS A COMPARATOR.

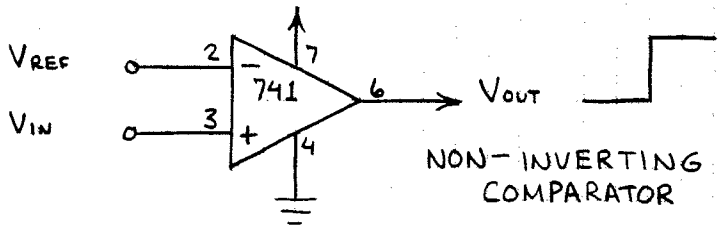

WHEN  $V_{IN}$  EXCEEDS  $V_{REF}$ , OUTPUT SWITCHES FROM LOW TO HIGH.

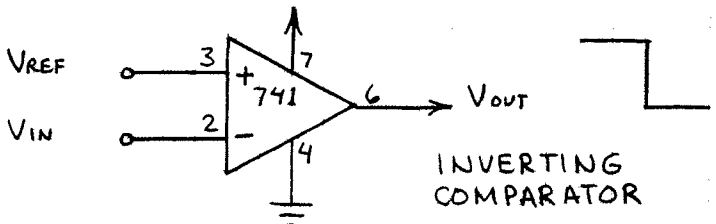

WHEN  $V_{IN}$  EXCEEDS  $V_{REF}$ , OUTPUT SWITCHES FROM HIGH TO LOW.

# BASIC COMPARATOR (CONT.)

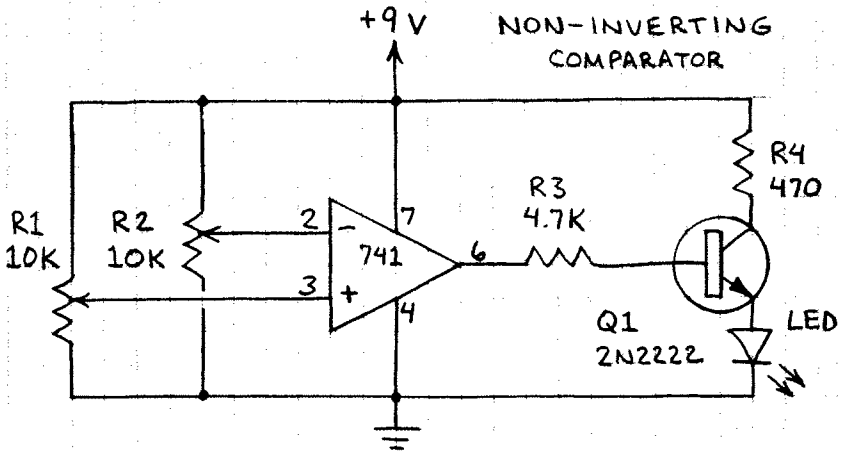

BUILD THIS SIMPLE CIRCUIT ON A PLASTIC BREADBOARD TO LEARN BASICS OF THE COMPARATOR. R1 AND R2 FUNCTION AS VOLTAGE DIVIDERS THAT SUPPLY A RANGE OF VOLTAGES TO BOTH 741 INPUTS. Q1 SWITCHES CURRENT TO THE LED WHEN THE OUTPUT OF THE 741 GOES HIGH. THE CIRCUIT WORKS LIKE THIS:

ASSUME R2 IS SET TO ITS CENTER POSITION TO GIVE  $V_{REF} = 4.5$  VOLTS ( $9V/2 = 4.5V$ ). R1 THEN CONTROLS  $V_{IN}$ .

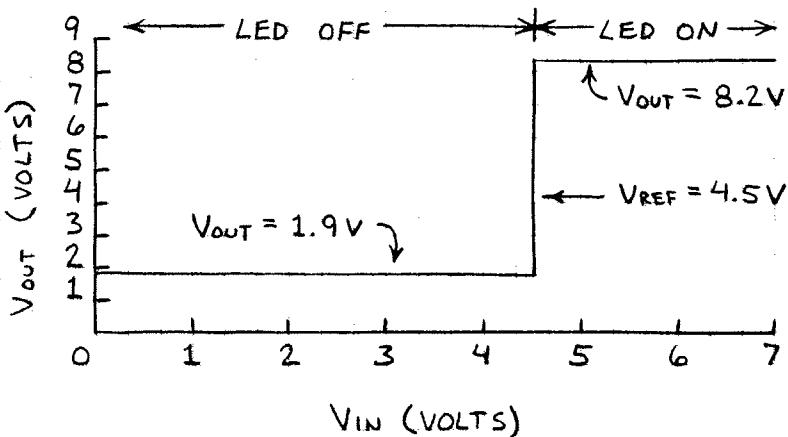

# BASIC WINDOW COMPARATOR

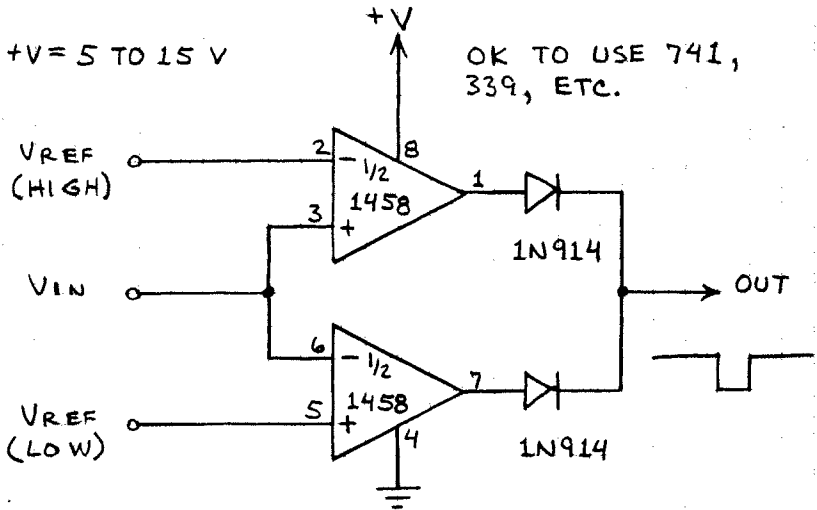

THIS IS AMONG THE MOST VERSATILE OF COMPARATOR CIRCUITS. ASSUME  $V_{REF} \text{ (HIGH)}$  IS 5.5 VOLTS AND  $V_{REF} \text{ (LOW)}$  IS 2.5 VOLTS. CIRCUIT THEN OPERATES LIKE THIS:

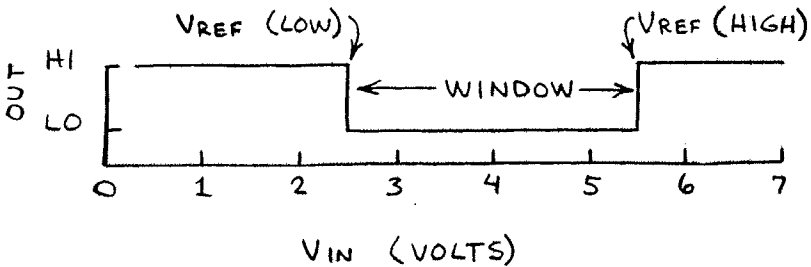

ONE OR BOTH REFERENCE VOLTAGES CAN BE SUPPLIED BY A VOLTAGE DIVIDER:

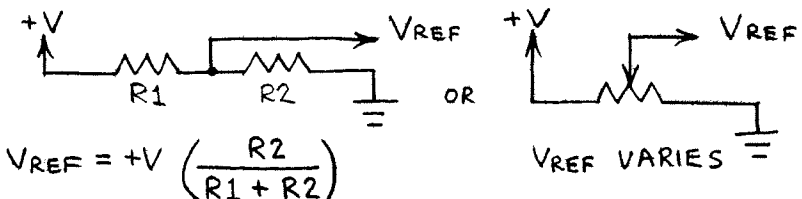

# WINDOW COMPARATOR (CONT.)

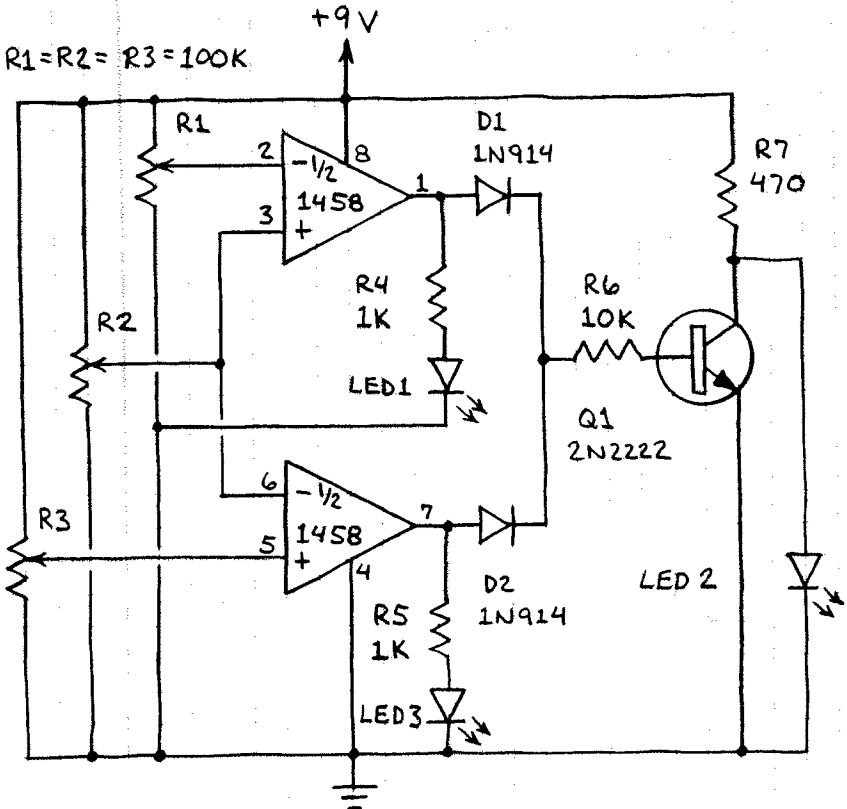

BUILD THIS CIRCUIT ON A BREADBOARD TO LEARN BASICS OF THE WINDOW COMPARATOR. USE VOLTMETER TO SET  $V_{REF}$  HIGH ( $R1$ ) AND  $V_{REF}$  LOW ( $R3$ ). (CONNECT PROBES ACROSS PIN 2 OF 1458 AND GROUND; ADJUST  $R1$ . REPEAT FOR PINS 5 AND GROUND; ADJUST  $R3$ .) ADJUST  $R2$  TO VARY  $V_{IN}$ .

$V_{IN}$  AT OR ABOVE  $V_{REF}$  HIGH: LED 1 ON  
 $V_{IN}$  WITHIN WINDOW: LED 2 ON  
 $V_{IN}$  AT OR BELOW  $V_{REF}$  LOW: LED 3 ON

WHEN  $V_{IN}$  IS BELOW 0.6 VOLT, BOTH LED 1 AND LED 3 SWITCH ON.

# 3-STEP SEQUENCER

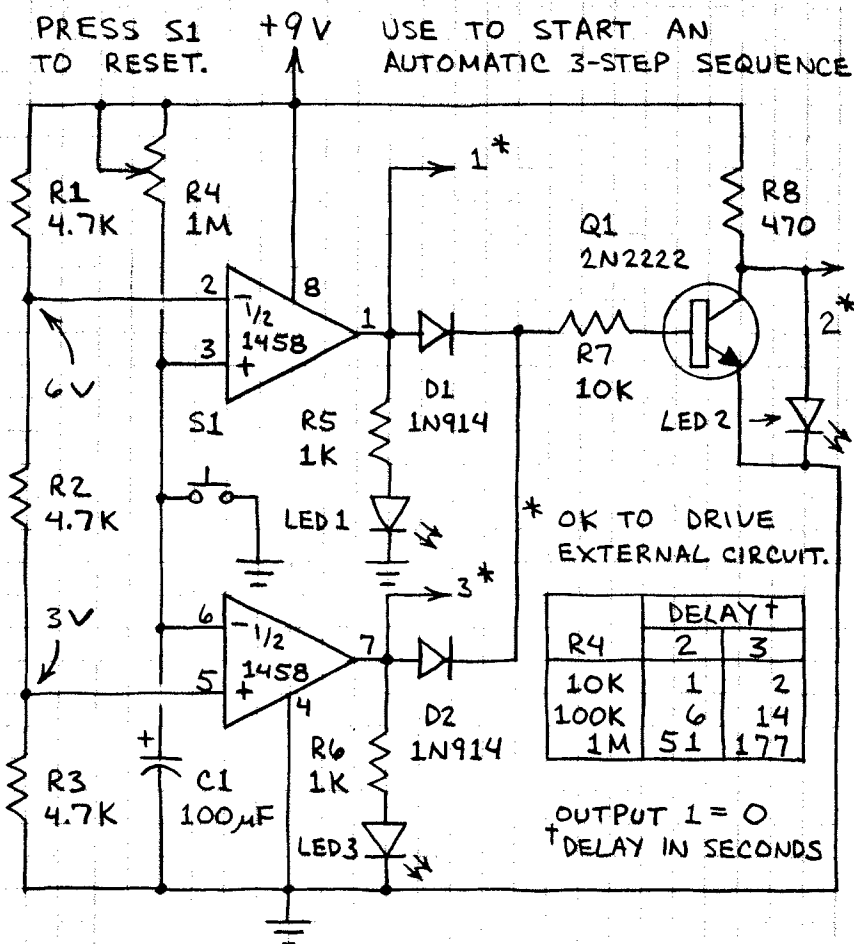

THIS IS A WINDOW COMPARATOR THAT SUPPLIES A 3-STEP SEQUENCE OF OUTPUT SIGNALS. PRESSING S1 DISCHARGES C1 AND LIGHTS LED 1 (AND LED 2 BRIEFLY). C1 THEN CHARGES THROUGH R4. AS CHARGE ON C1 PASSES 3 AND 6 VOLTS, LEDS 2 AND 3 GLOW IN SEQUENCE. REDUCE R2 TO BALANCE TIME DELAY SEQUENCE AND REDUCE DELAY TIME. DELAYS SHOWN WILL VARY WITH TOLERANCE OF C1.



# BARGRAPH VOLTMETER

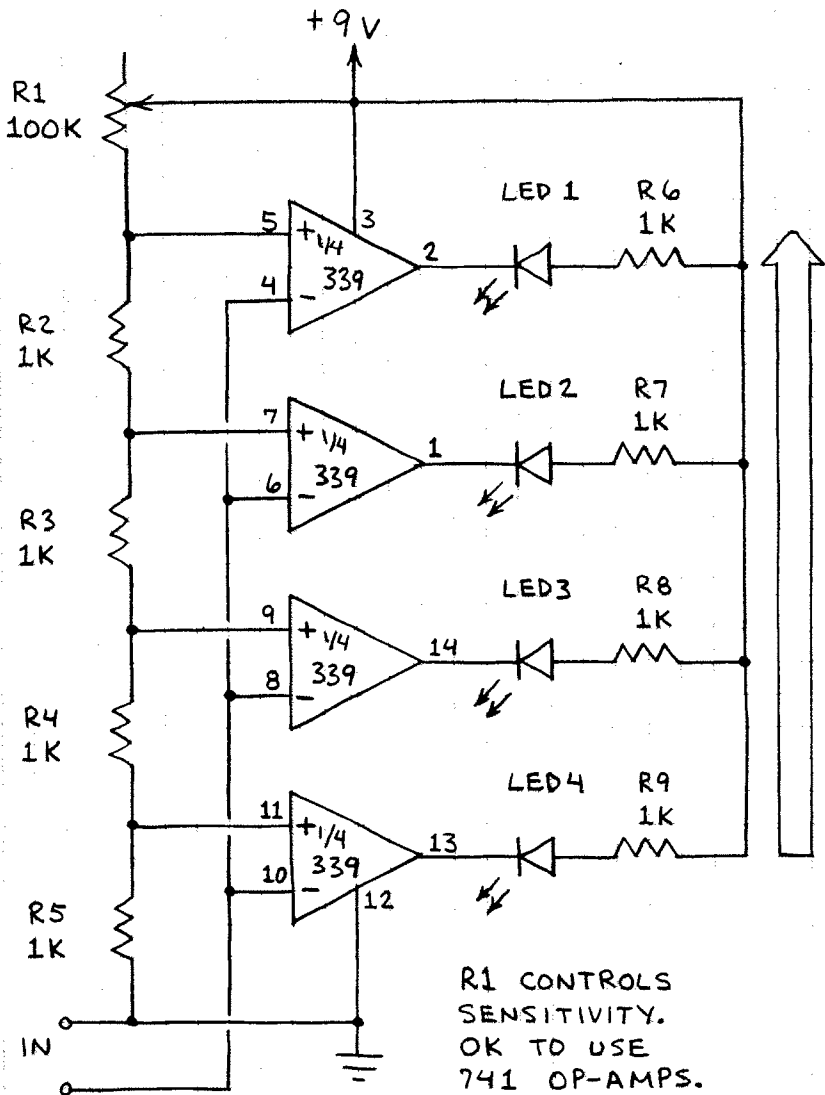

LEDS GLOW IN SEQUENCE AS INPUT VOLTAGE RISES. LEDES ALSO RESPOND TO CHANGE IN RESISTANCE AT INPUT. TOUCH INPUTS WITH FINGER TO OBSERVE. CONNECT CDS CELL ACROSS INPUTS TO MAKE LIGHTMETER.

# LIGHT-ACTIVATED RELAYS

## PHOTOTRANSISTOR:

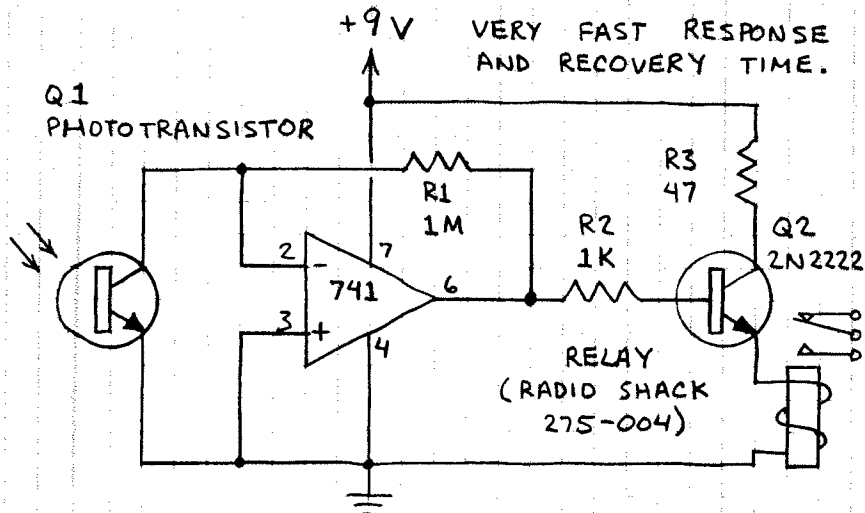

ILLUMINATE Q1 TO ACTIVATE RELAY.

## PHOTORESISTOR:

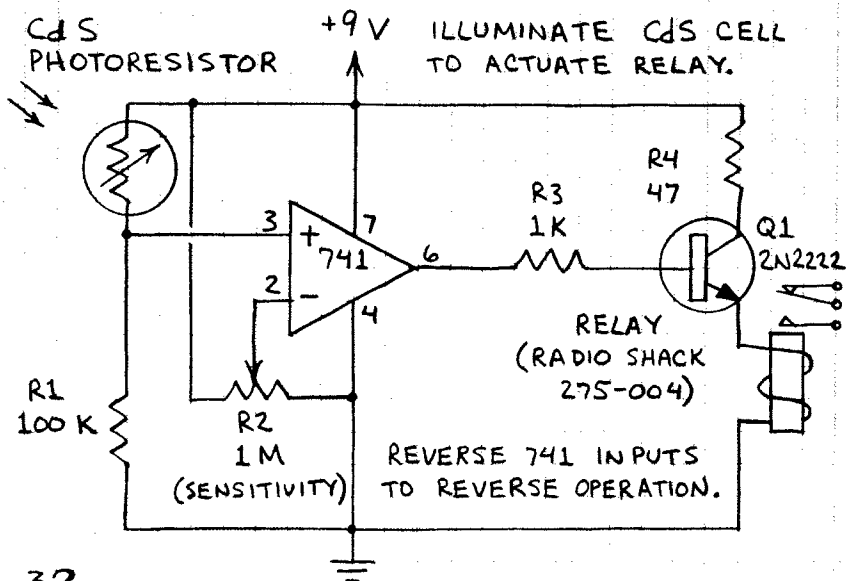

# LIGHT-ACTIVATED ALERTER

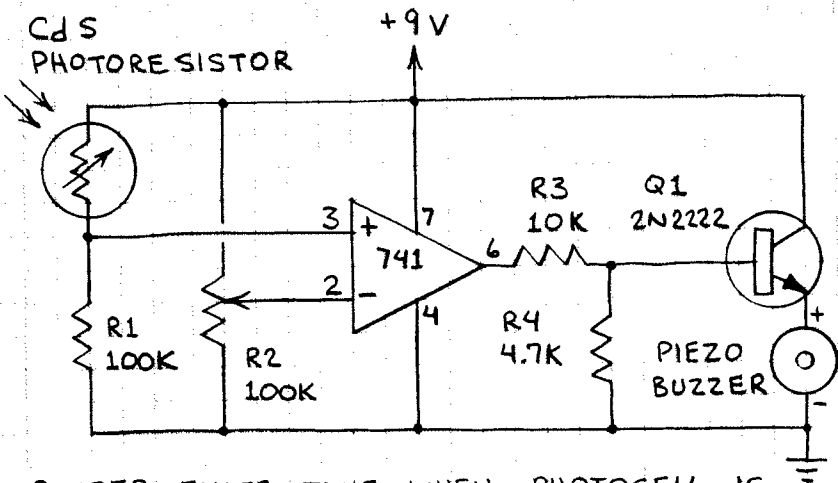

BUZZER EMITS TONE WHEN PHOTOCCELL IS ILLUMINATED. R2 CONTROLS SENSITIVITY. R4 KEEPS Q1 OFF UNTIL THE 741 OUTPUT GOES HIGH. USE AS SUN-ACTIVATED WAKEUP ALARM AND OPEN REFRIGERATOR DOOR ALARM.

# DARK-ACTIVATED ALERTER

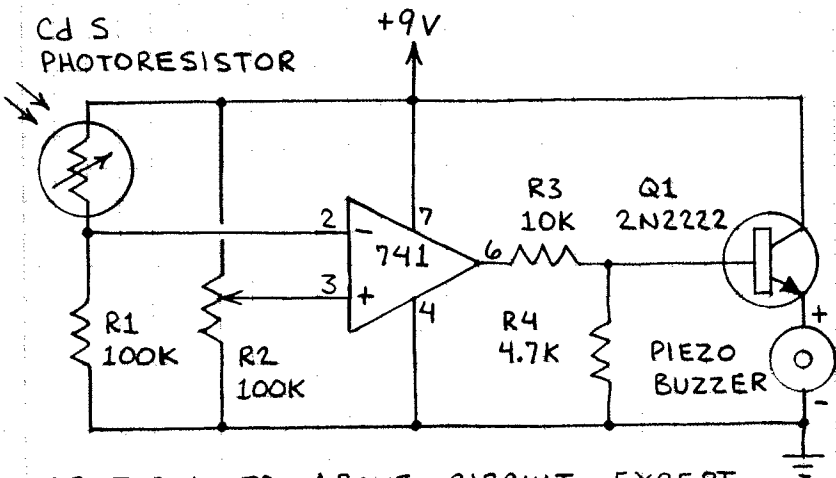

IDENTICAL TO ABOVE CIRCUIT EXCEPT INPUTS TO 741 REVERSED. OK TO REPLACE PIEZO BUZZER WITH RELAY (NO. 275-004).

# LIGHT-SENSITIVE OSCILLATORS

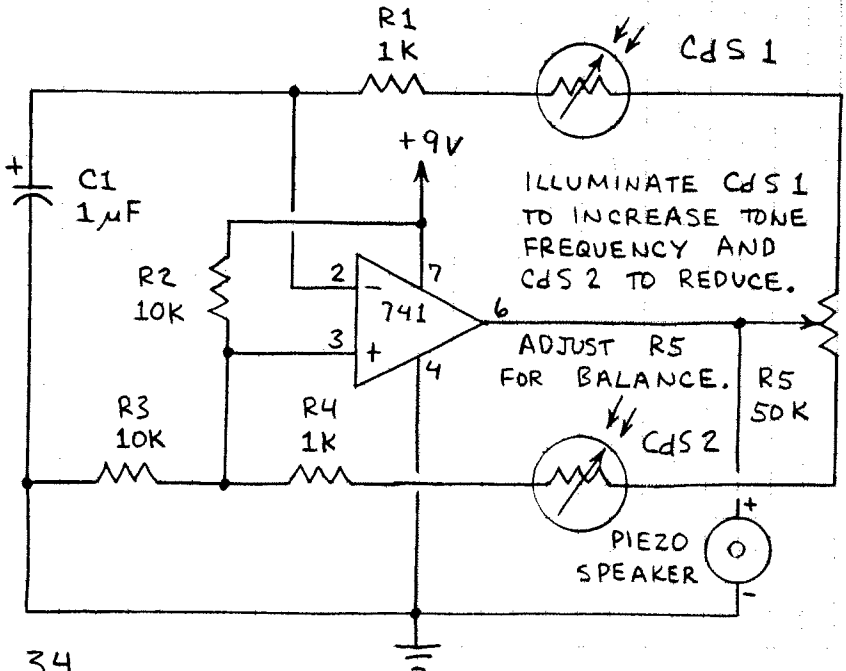
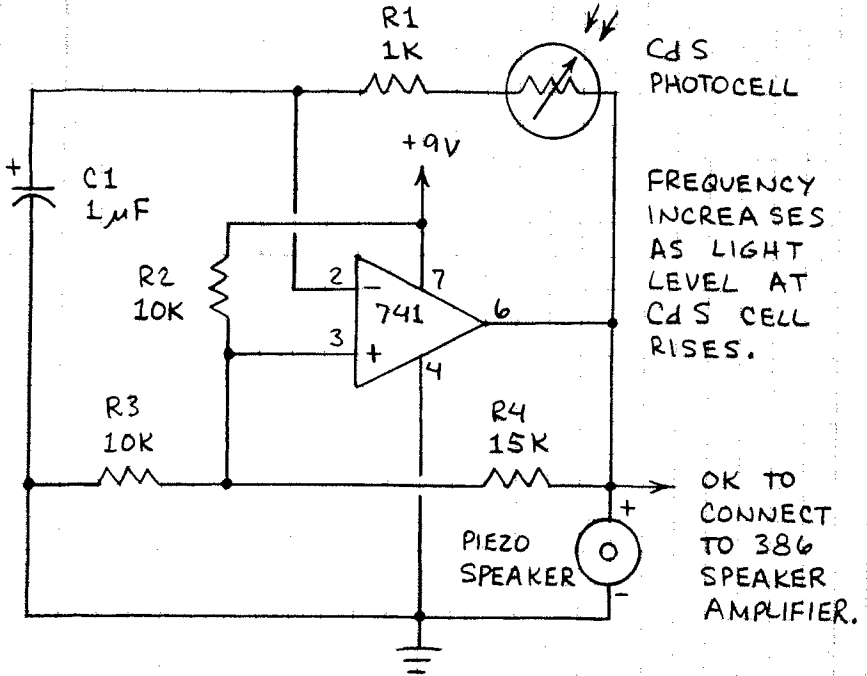

# HIGH-SENSITIVITY LIGHT METER

**CAUTION:**

THIS CIRCUIT IS VERY SENSITIVE. TOO MUCH LIGHT WILL "SLAM" THE NEEDLE OF AN ANALOG METER.

FULL-SCALE METER READINGS:

S1	METER
1	0-10 $\mu$ A
2	0-1 $\mu$ A
3	0-0.1 $\mu$ A

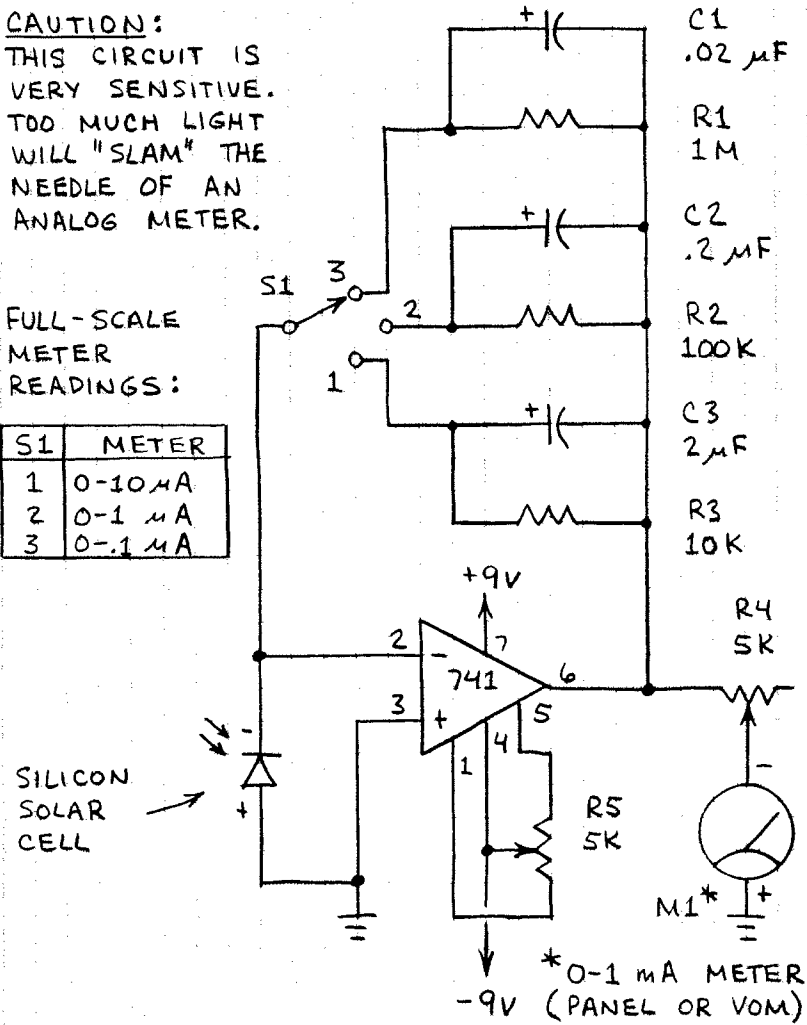

THIS CIRCUIT IS BASED UPON THOSE USED IN SOME PRECISION, LABORATORY-QUALITY LIGHT METERS. TO ZERO METER, CONNECT PIN 2 TO GROUND AND ADJUST OFFSET (R5) UNTIL METER READS 0. THEN DISCONNECT PIN 2 FROM GROUND. R4 IS AN OPTIONAL CONTROL FOR ALTERING SENSITIVITY OF THE CIRCUIT.

# SOUND-LEVEL METER

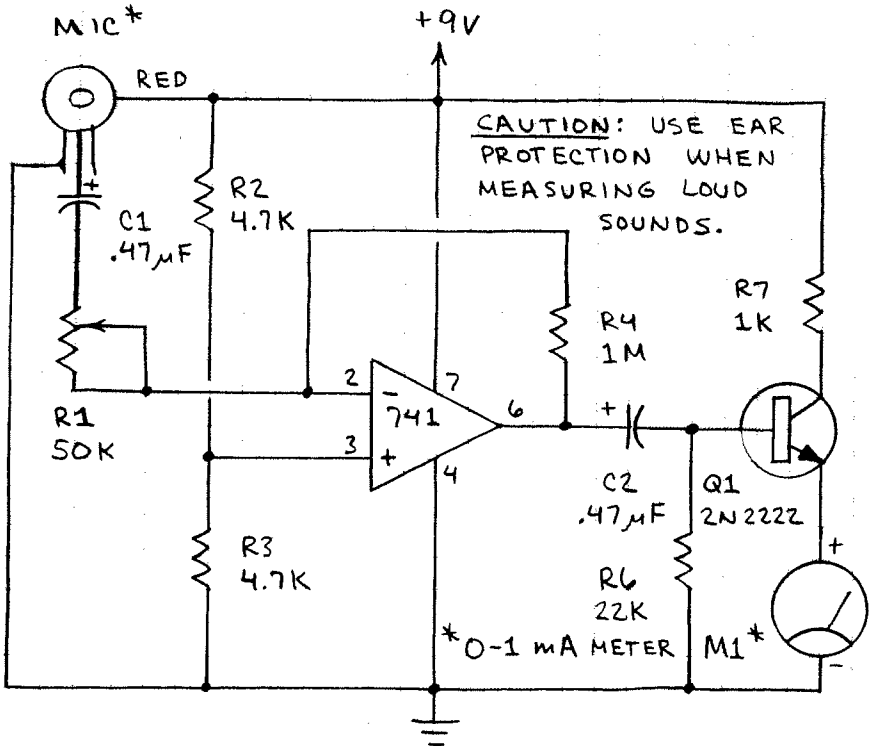

\* MICROPHONE (RADIO SHACK 270-092 OR SIMILAR).

THIS SIMPLE CIRCUIT IS AN EFFECTIVE SOUND-LEVEL METER. R1 CONTROLS THE GAIN OF THE 741 OP-AMP, HENCE THE SENSITIVITY OF THE CIRCUIT. THE METER CAN BE A PANEL METER OR A MULTIMETER SET TO READ CURRENT. THE CIRCUIT WAS TESTED WITH A PIEZO BUZZER THAT EMITTED A 6.5 KHZ TONE AT A SOUND PRESSURE OF 90dB. WHEN THE BUZZER WAS 2" FROM THE MICROPHONE AND R1 WAS SET FOR MAXIMUM GAIN, THE METER INDICATED 1 mA. AT 12" THE OUTPUT FELL TO 0.4 mA. NORMAL SPEECH AT 12" GAVE FLUCTUATING SIGNAL UP TO 10 µA.

# SOUND-ACTIVATED RELAY

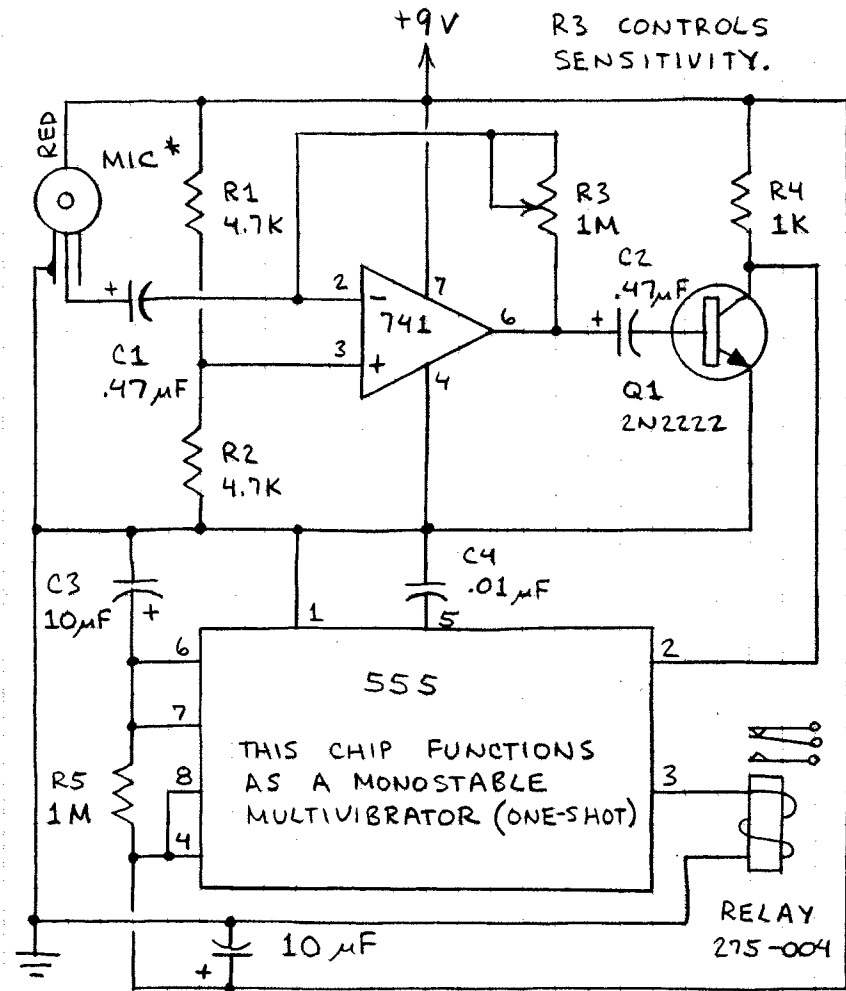

\* MICROPHONE (RADIO SHACK 270-092 OR SIMILAR).

THIS CIRCUIT TRIPS RELAY IN RESPONSE TO LOUD SOUND (VOICE, CLAP, ETC.). R5 AND C3 CONTROL TIME RELAY STAYS PULLED IN (VALUES SHOWN GIVE ~12 SECONDS). IMPORTANT: USE 0.1µF CAPACITOR ACROSS POWER SUPPLY PINS OF BOTH THE 741 AND 555. REDUCE RESISTANCE OF R3 TO REDUCE SENSITIVITY.

# PIEZO ELEMENT DRIVERS

## GATED:

V = +5 TO 12 VOLTS

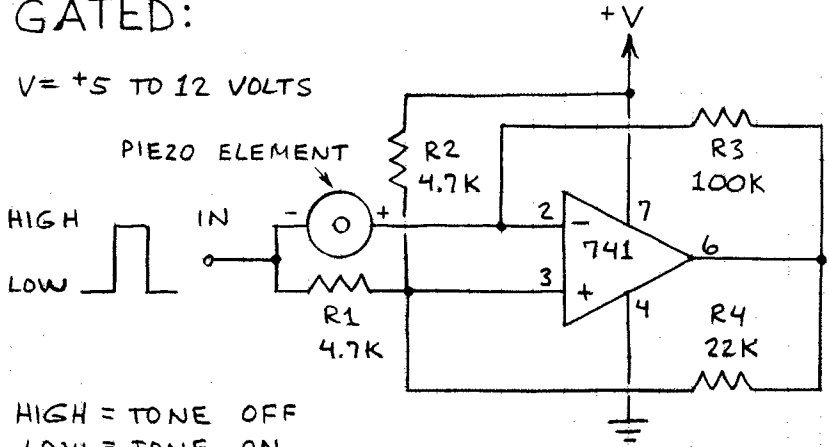

HIGH = TONE OFF  
LOW = TONE ON

THIS CIRCUIT IS AN ASTABLE MULTIVIBRATOR IN WHICH A PIEZO ELEMENT DOUBLES AS THE TIMING CAPACITOR AND THE TONE SOURCE. TRIGGER WITH LOGIC SIGNAL OR BY CONNECTING SWITCH FROM INPUT TO GROUND.

## VARIABLE FREQUENCY

V = +3 TO +15 V

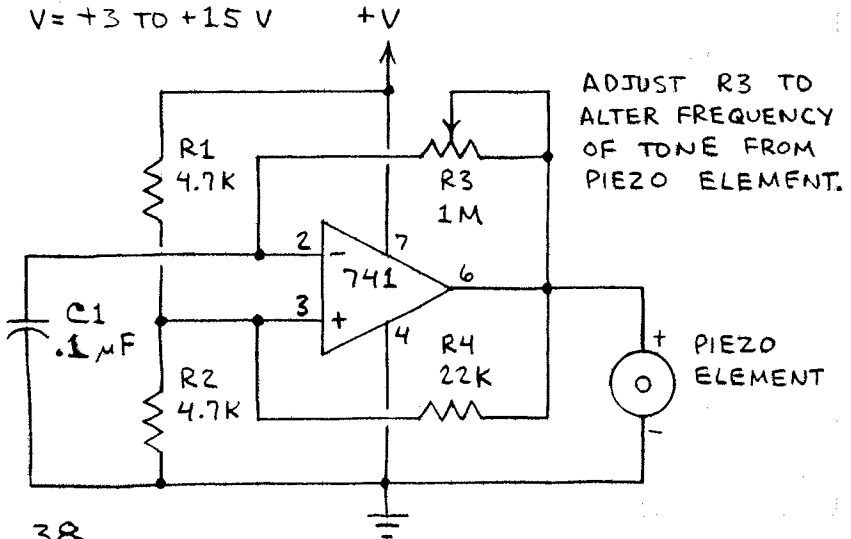

ADJUST R3 TO ALTER FREQUENCY OF TONE FROM PIEZO ELEMENT.



# PERCUSSION SYNTHESIZER

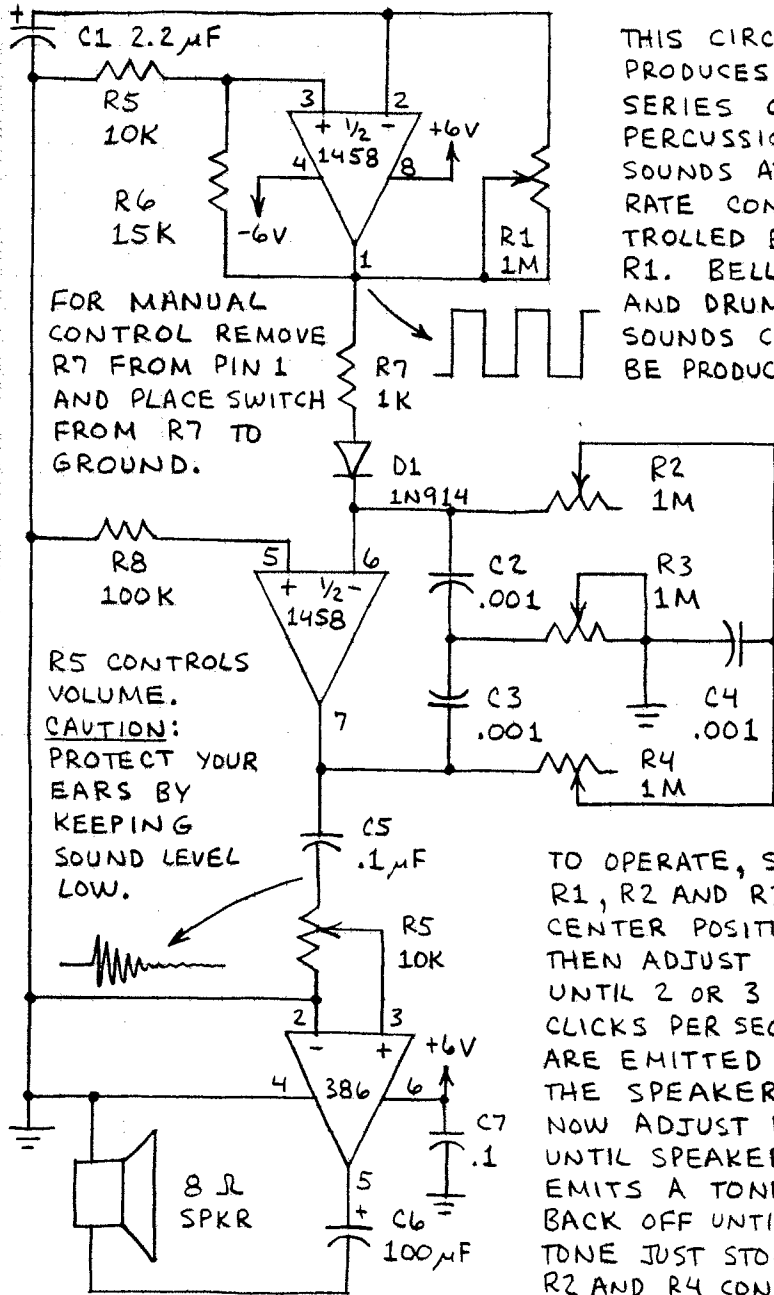

THIS CIRCUIT PRODUCES A SERIES OF PERCUSSION SOUNDS AT A RATE CONTROLLED BY R1. BELL AND DRUM SOUNDS CAN BE PRODUCED.

FOR MANUAL CONTROL REMOVE R7 FROM PIN 1 AND PLACE SWITCH FROM R7 TO GROUND.

R5 CONTROLS VOLUME. CAUTION: PROTECT YOUR EARS BY KEEPING SOUND LEVEL LOW.

TO OPERATE, SET R1, R2 AND R3 TO CENTER POSITIONS. THEN ADJUST R1 UNTIL 2 OR 3 CLICKS PER SECOND ARE EMITTED BY THE SPEAKER. NOW ADJUST R3 UNTIL SPEAKER EMITS A TONE. BACK OFF UNTIL TONE JUST STOPS. R2 AND R4 CONTROL PITCH.

# LOW-PASS FILTER

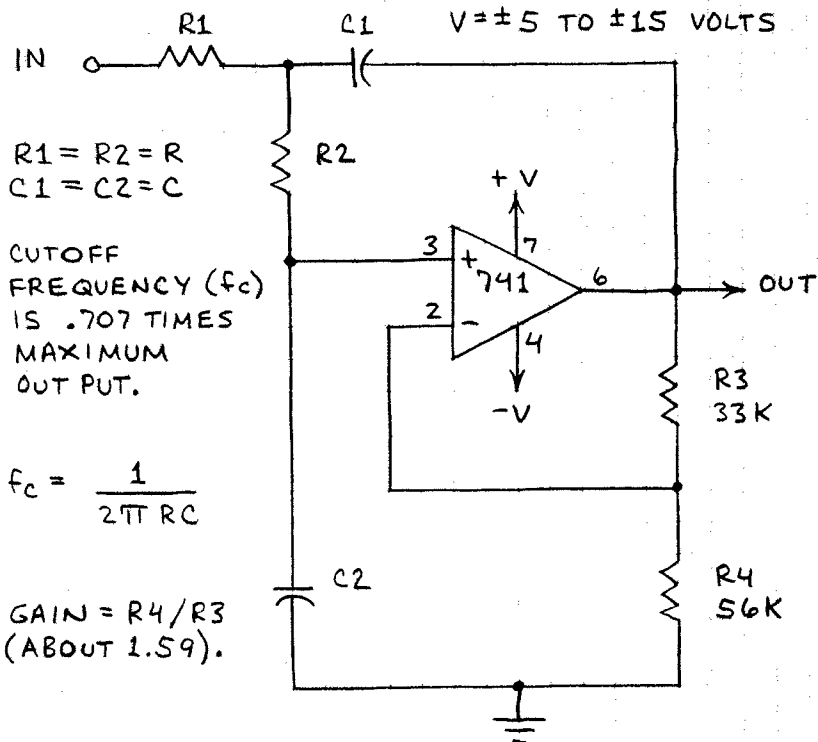

THIS IS AN EQUAL COMPONENT SALLEN-KEY FILTER.  $R3$  SHOULD BE  $.586 \times R4$ . SHOWN BELOW IS RESPONSE OF FILTER WHEN INPUT WAS A 1-VOLT SINE WAVE:

$R = 4,700 \Omega$       CALCULATED  $f_c = 3,386 \text{ Hz}$   
 $C = .01 \mu F$       MEASURED  $f_c = 3,000 \text{ Hz}$

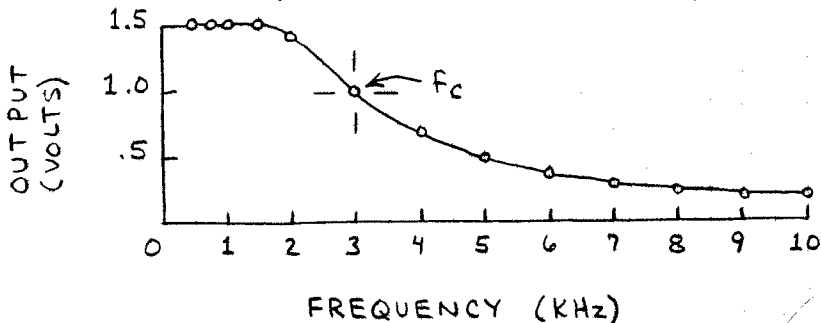

# HIGH-PASS FILTER

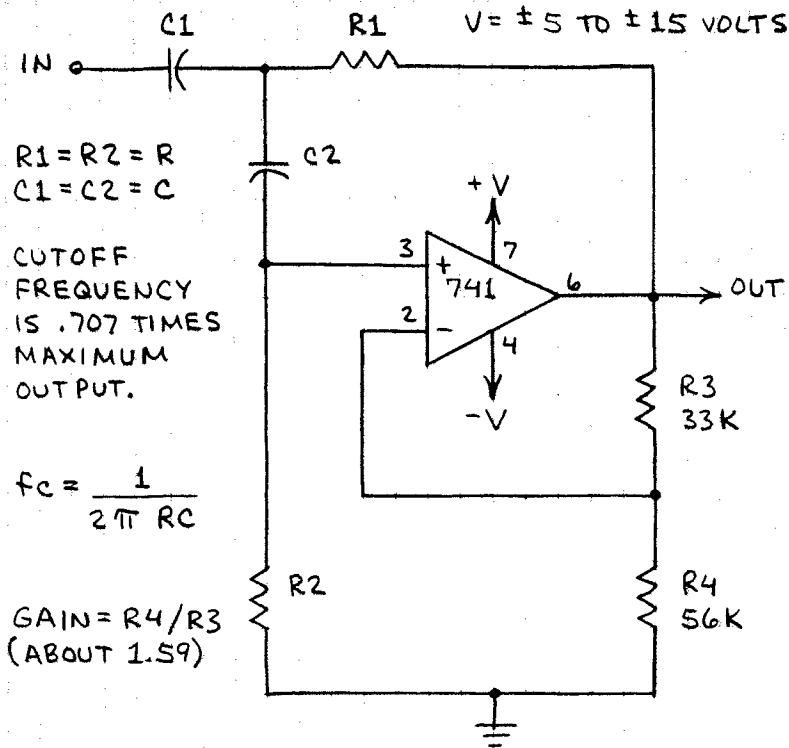

THIS CIRCUIT IS IDENTICAL TO THE EQUAL COMPONENT Sallen-Key Filter on facing page except  $R1$  and  $R2$  and  $C1$  and  $C2$  have been interchanged. Below is response when input was a 1-volt sine wave:

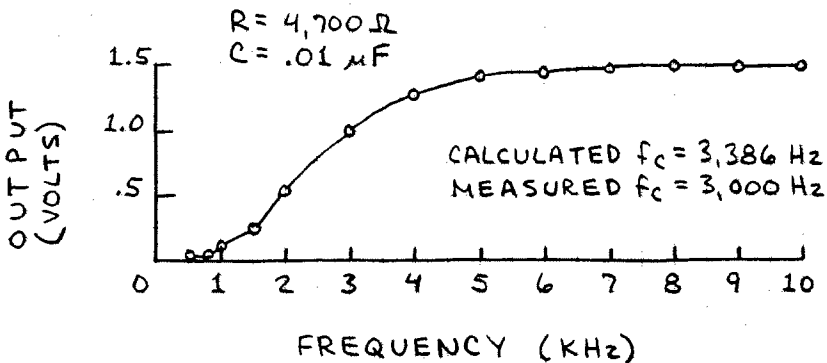

# 60-HZ NOTCH FILTER

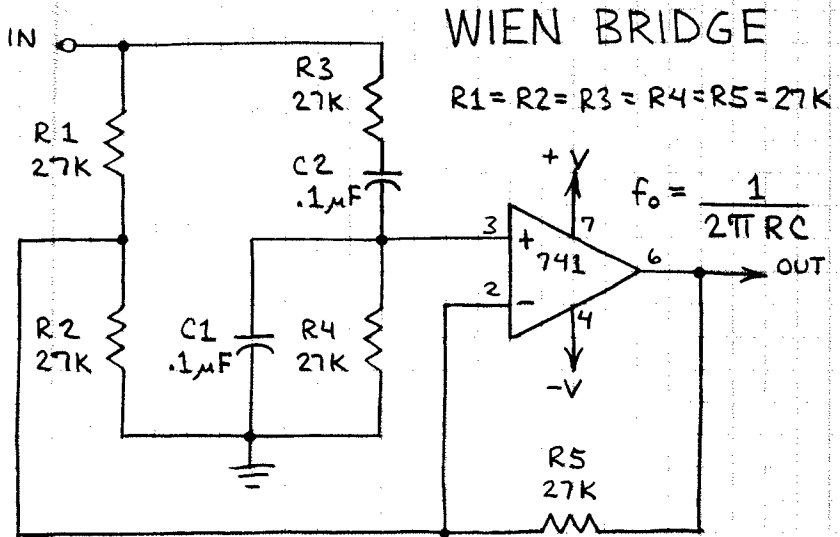

## TWIN TEE

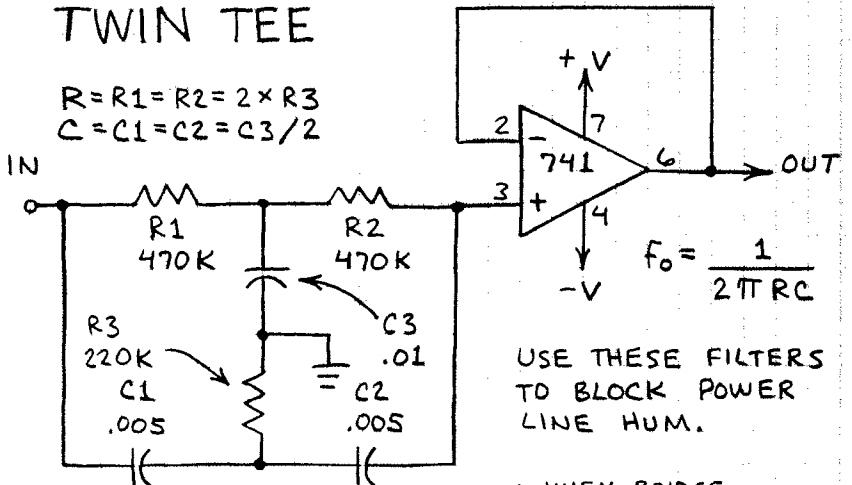

USE THESE FILTERS  
 TO BLOCK POWER  
 LINE HUM.

○ WIEN BRIDGE

● TWIN TEE

GRAPH SHOWS  
 RESULTS FOR  
 TEST VERSIONS  
 OF BOTH FILTERS.  
 INPUT WAS 1-VOLT  
 PEAK-TO-PEAK SINE WAVE.

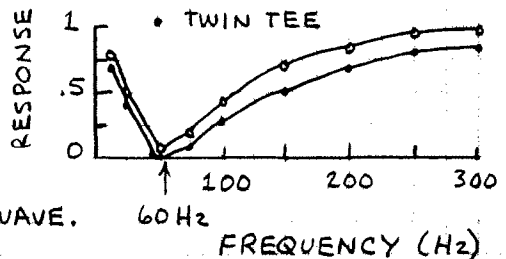

# TUNABLE BANDPASS FILTER

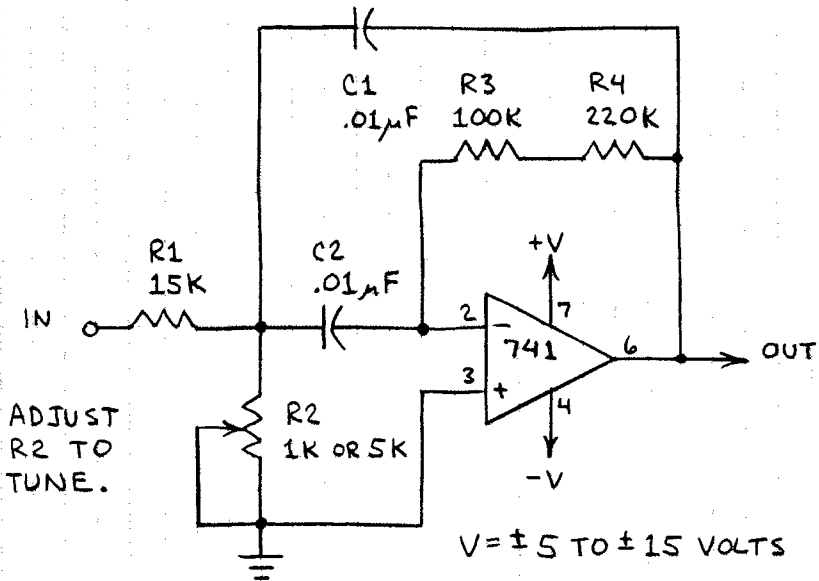

THIS FILTER CAN BE TUNED BY R2 TO PASS A NARROW FREQUENCY BAND BETWEEN A FEW HUNDRED HZ AND ABOUT 3,000 HZ. USE TO DETECT PRESENCE OF A TONE IN A SIGNAL. ACTUAL RESPONSE TO A 1-VOLT SINE WAVE:

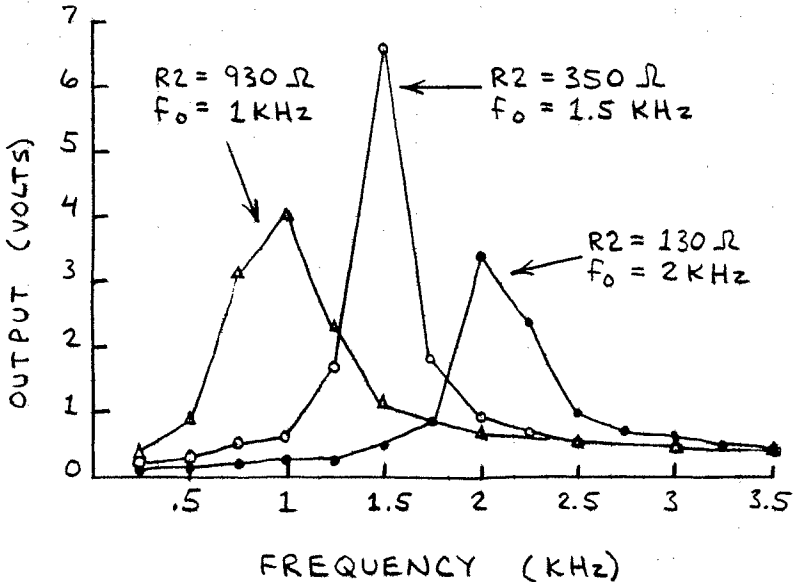

# MINI-COLOR ORGAN

THIS ARRAY OF ACTIVE FILTERS WILL CONVERT THE AUDIO SIGNAL FROM A SMALL RADIO OR TAPE PLAYER INTO A FLICKERING PATTERN OF COLORS. R2 CONTROLS GAIN OF THE INPUT AMPLIFIER BELOW. USE RADIO/TAPE PLAYER VOLUME CONTROL AND R2 TO ADJUST INTENSITY OF LEDs.

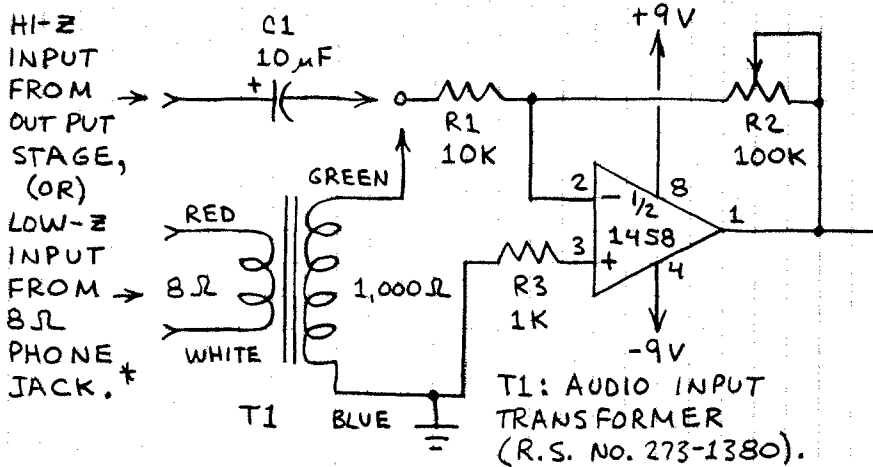

\* INSERT PHONE PLUG CONNECTED TO T1 PART WAY IN PHONE JACK SO SPEAKER WILL NOT BE SWITCHED OFF.

LEDs VARY IN BRIGHTNESS. EXPERIMENT WITH DIFFERENT LEDs FOR BEST RESULTS. HERE IS ACTUAL RESPONSE OF CIRCUIT:

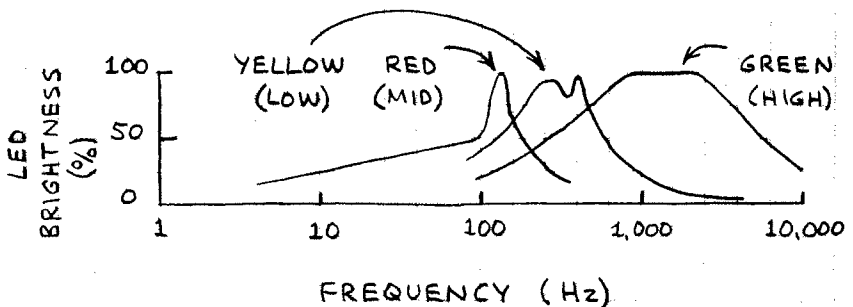

# MINI-COLOR ORGAN (CONT.)

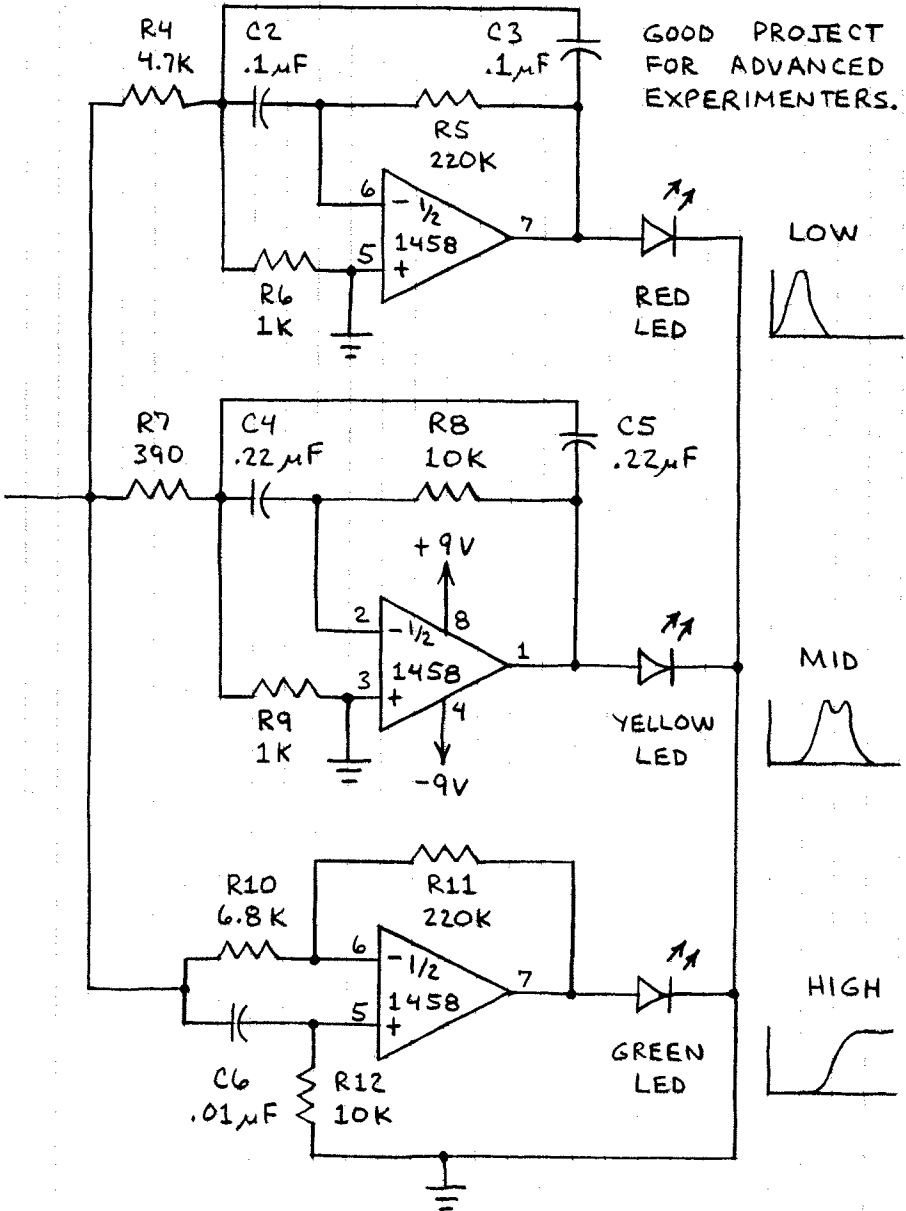

REDUCE R4 AND R7 TO INCREASE RED AND YELLOW BRIGHTNESS. INCREASE R11 TO INCREASE GREEN BRIGHTNESS.

# SQUARE WAVE GENERATOR

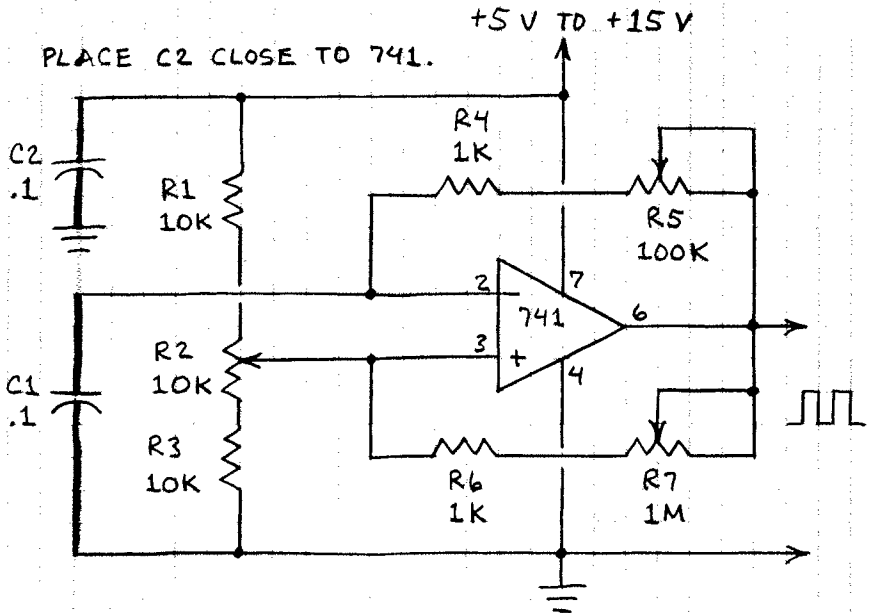

THIS CIRCUIT IS AN EASILY ADJUSTABLE SQUARE WAVE GENERATOR. THE TIMING COMPONENTS ARE C1, R4, R5, R6 AND R7. R1-R2-R3 CONTROL THE DURATION (OR "WIDTH") OF THE PULSES. THE PULSES ARE SYMMETRICAL WHEN R2 IS AT ITS CENTER POSITION. OK TO CONNECT R2 DIRECTLY TO +V AND  $\frac{1}{2}$ , THEREBY ELIMINATING R1 AND R3. TYPICAL RESULTS:

C1	FREQUENCY
.001	11,480 Hz
.047	3,848 Hz
.01	2,155 Hz
.047	462 Hz
.1	227 Hz
.47	45 Hz
1.0	24 Hz

FOR THESE RESULTS, R1-R2-R3 REPLACED BY 4.7K FROM PIN 3 TO +V AND 4.7K FROM PIN 3 TO GROUND. R4+R5 = 100K, R6+R7 = 22K, AND +V = +12 VOLTS.

OK TO ADD FOLLOWER STAGE TO BUFFER OUTPUT.



# SINE WAVE OSCILLATOR

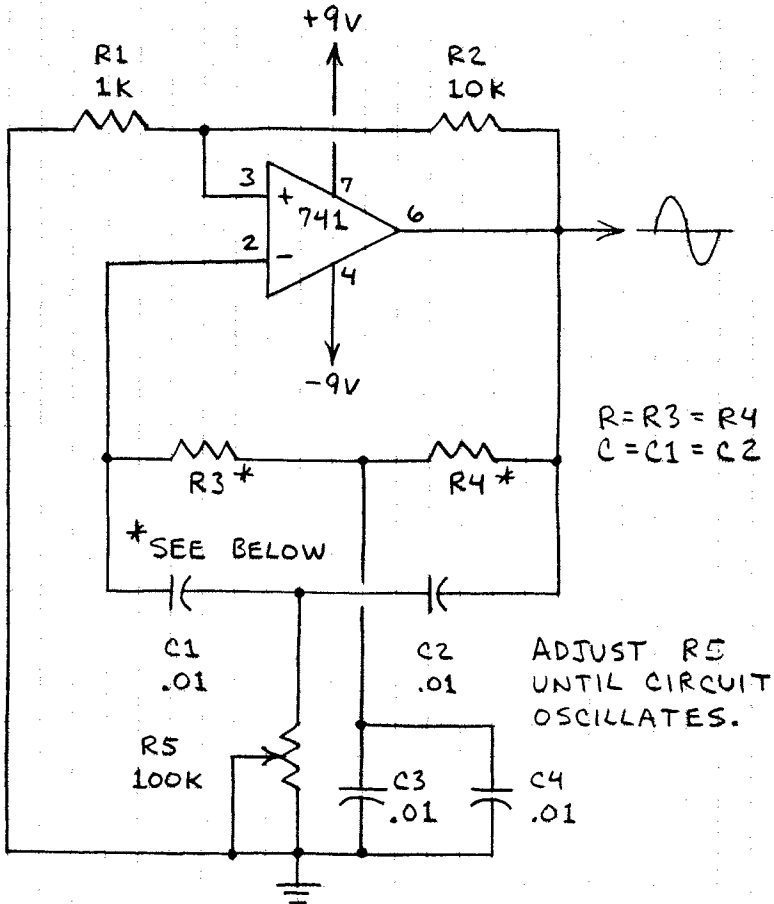

R3, R4, R5, C1, C2, C3, AND C4 FORM A TWIN-TEE FILTER. WHEN CONNECTED IN THE FEEDBACK LOOP OF AN OP-AMP, THE RESULTING CIRCUIT GENERATES A SINE WAVE. THE FREQUENCY IS  $1/(2\pi RC)$ .

TYPICAL RESULTS  
FROM TEST  
CIRCUIT:

R3 = R4	FREQUENCY
4.7 K	2926 Hz
10 K	1356 Hz
15 K	927 Hz

# FUNCTION GENERATOR

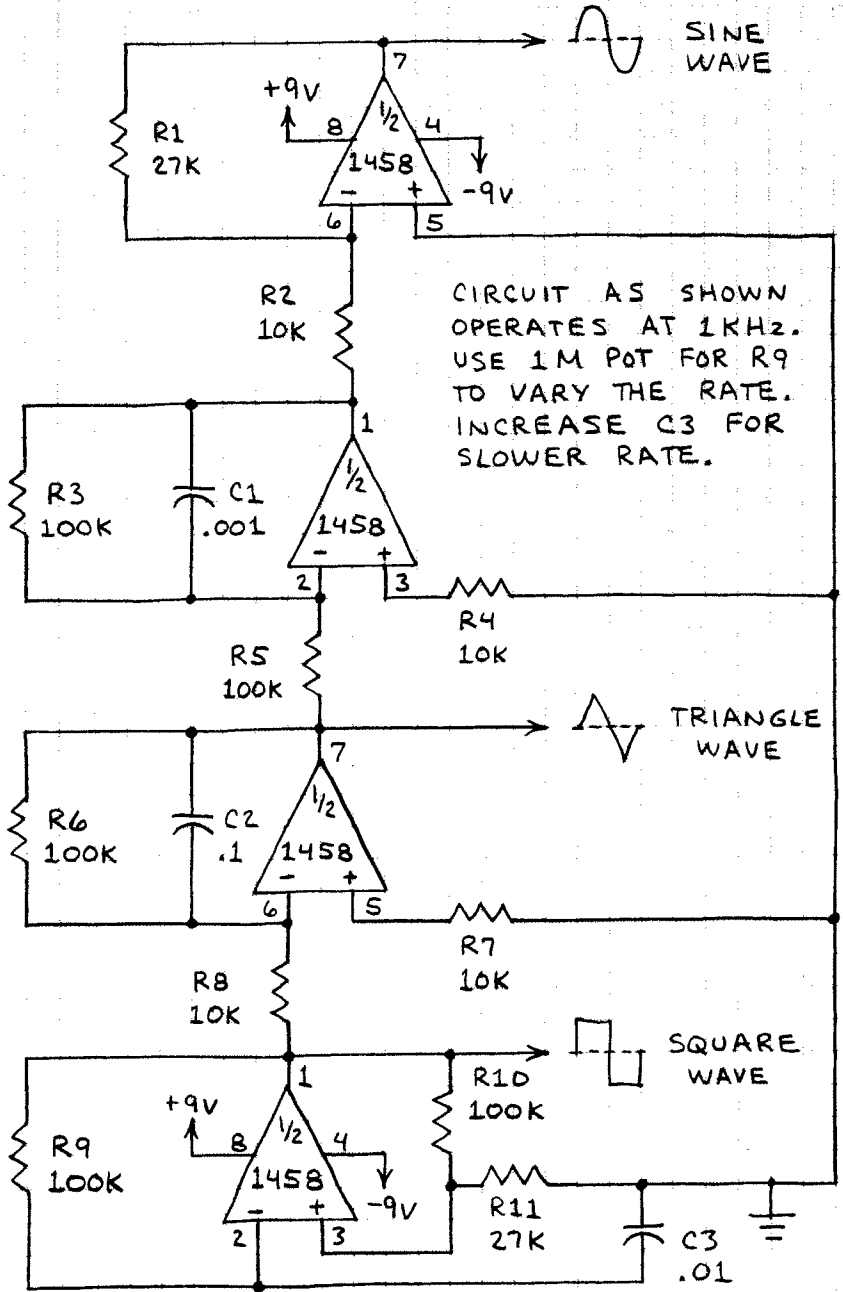



**Radio Shack**

A Division of Tandy Corporation  
Fort Worth, TX 76102

PRINTED IN U.S.A.

